

Reducing windthrow losses in Farm Forestry

Authors

J. Mulqueen¹, J. McHale² and M. Rodgers²

¹Teagasc Research Centre, Athenry Co. Galway

²National University of Ireland Galway

Teagasc acknowledge with gratitude the support of European Union Structural Funding (EAGGF) in financing this research project.

ISBN

May 1999

CONTENTS

SUMMARY	ii
INTRODUCTION	1
FIELD TESTING	3
SIMPLE SHEAR TESTING	8
COMPUTER AIDED MODELLING	12
CONCLUSIONS	15
REFERENCES	17

SUMMARY

The study comprised a field and laboratory investigation on the stability of Sitka spruce trees planted on a surface water gley.

The field-testing was conducted at Ballyfarnon Forest in County Sligo in the north west of Ireland. Nine destructive monotonic pulling tests were conducted on trees selected from three different site preparations, namely, mole drained, double mouldboard ploughed and an uncultivated control. Dynamic testing, using a mechanical rocking device, was performed on a tree selected from the uncultivated control.

A simple shear apparatus was used to conduct monotonic and cyclic tests on reconstituted samples of the Ballyfarnon soil. This allowed a comparison of soil behaviour under monotonic and cyclic loading.

A computer software package was used to model the behaviour of groundwater for soil mole drained at two drain spacings. Results from this mathematical modeling were compared to experimental data gathered during a previous study.

Results indicate that the use of mole drainage as a site preparation technique produces more stable trees than either double mouldboard ploughing or no cultivation.

INTRODUCTION

Forestry and its associated activities provide an increasingly important contribution to the Irish economy. As with all crops extreme weather events such as storms can cause severe damage on occasion. One of the major problems afflicting forestry is the phenomenon of *windthrow*, which occurs when the stem and rootplate of a tree overturn (with the rootplate remaining substantially intact). The economic losses incurred due to the substantial volumes of lost timber, increased harvesting cost, increased disease risk and the increased accident risk during harvesting of wind damaged crops are substantial. Losses run to approximately IR£1m. The risk of a tree being windthrown increases with increasing tree height; in the case of Sitka spruce trees this becomes particularly pronounced after the trees reach heights of 15 m and over.

Windthrow is caused by the failure of poorly drained soil beneath the root plates to anchor the trees. In Ireland, it was estimated that windthrow caused direct financial losses of £11 m during the period 1987-1997 (E. Hendrick, personal communication). Windthrow can also result in increased soil erosion, run-off and adverse visual impact. Its occurrence depends on tree type and a number of site factors, which include soil type, soil drainage, soil strength, elevation, aspect and location.

Ballyfarnon Forest was chosen for the study as it was representative of forests which were historically prone to windthrow, and it had experimental plots with three different site preparations located within it. The forest is located approximately 32 km south east of Sligo town in County Sligo. The tree species is Sitka spruce and the soil type is a surface water gley. These soils have very low permeabilities and therefore the water table is close to

the ground surface for much of the year. This high water table limits the depth of rooting of the trees, predisposing them to windthrow.

Within the forest an experiment was established to ascertain the effect of drainage on the stability of trees against storms. For this study, tests were conducted in three of the experimental plots namely:

- (i) mole drained,
- (ii) double mouldboard (DMB) ploughed
- (iii) an undrained control plot.

Mole drains are unlined tunnels formed within the soil. During installation, the soil at some point above the mole drain is broken and cracked. The cracks increase the permeability of the soil and allow excess water to drain away rapidly thereby controlling the water table. At Ballyfarnon forest the mole drains were installed to a depth of 0.45 m, had a diameter of 0.075 m and were spaced at 2 m intervals.

During double mouldboard ploughing a 0.3 m deep furrow is formed with the excavated soil being laid as ribbons on either side of the furrow. The seedlings are then planted into the ribbons of upturned soil with each line of trees being 2 m apart.

The following sections summarise the field and laboratory tests that were conducted to study the mechanisms by which windthrow occurs and to attempt to identify the method of drainage which gives the greatest tree anchorage and stability against windthrow.

FIELD TESTING

The field testing comprised:

- (i) monotonic destructive tree pulling tests
- (ii) repeated forced loading tests.

Monotonic destructive tree pulling tests involved the application of a monotonic load to a tree, normally until failure of the rootplate occurred. The diameter at breast height (dbh, the diameter of the tree stem measured at a height of 1.3 m above the ground surface) was approximately the same for each of the trees tested. The relevance of this form of testing to windthrow is to quantify the degree and the nature of root anchorage. As the loads are applied slowly the testing is not representative of wind loading. The loads were applied using a winch and wire rope arrangement. A load cell was incorporated to measure the tensile loads generated during tree pulling. One end of the wire rope was attached to the top of a tree stem that had been truncated at a height of 6 m. The winch and load cell were positioned at the opposite end of the rope which had been secured to the bottom of a second “anchor” tree. The wire rope was marked at equal intervals along its length. As the test stem was winched over, the load, as measured by the load cell, was recorded as each interval mark was passed. Pulling continued until the rootplate had clearly failed. Three trees from each of the experimental plots were tested in this fashion.

Knowing the distance from the test tree to the anchor tree and the measured loads the bending moments generated at the base of the test stem were calculated. The bending moments were then plotted against the displacement of the stem top. The maximum bending moment recorded was noted for each tree and was considered to reflect the degree of anchorage of

the trees. Figure 1 shows the results obtained for three trees, one from each of the three experimental plots.

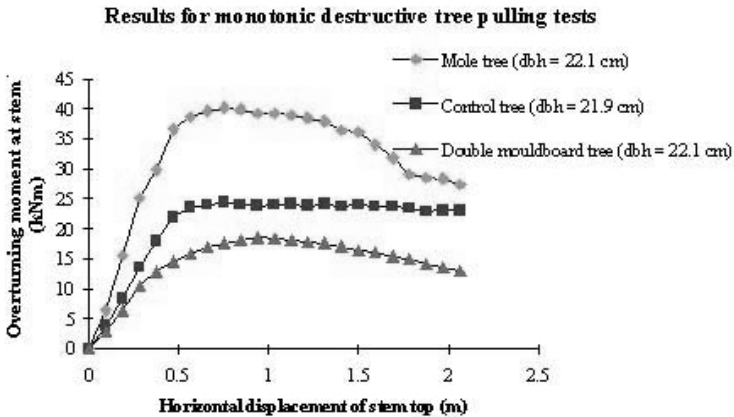

Fig. 1. Combined results of three tests.

The results from this study were combined with those from a previous study giving six results for each of the experimental plots. This allowed a statistical analysis to be conducted. The combined results are summarised in Table 1. The differences between the average values of the maximum overturning moments were checked for significance. The mean overturning moment required for uprooting in the mole drained plot was significantly greater ($P = 0.01$) than the mean value required for uprooting in the double mouldboard ploughed plot. The mean value for the mole drained plot was also significantly ($P = 0.05$) greater than the mean value for the control plot. The mean for the control plot was significantly greater ($P = 0.1$) than the mean for the double mouldboard plot. These results clearly demonstrate the improved anchorage as a result of planting on the mole drained plot.

One tree was tested dynamically, from the control plot. As in the case of the destructive tree pulling tests, the tree was truncated at a height of 6 m and pruned. The tree was subjected to dynamic loading conditions by a mechanical rocking device. The responses of the trees were measured and recorded using a data logging system, as several instruments needed to be read simultaneously and the responses changed quickly. The device used to impart the dynamic loads during testing had been developed for a previous study by Rodgers *et al.* (1995). The major advantage of such a mechanical rocking device was that it allowed testing to proceed in the absence of suitably high winds.

Table 1: Summary of destructive tree pulling tests

Plot	Tree no.	Tree diameter ¹	Maximum overturning moment	Mean±s.e.
Mole	1	22.5	29.2	32.23±5.06
	2	22.7	27.2	
	3	22.1	33.1	
	4	22.2	27.9	
	5	22.0	35.6	
	6	22.1	40.1	
Control	1	22.1	27.3	24.48±3.98
	2	21.3	19.1	
	3	21.1	19.4	
	4	22.1	26.9	
	5	21.9	24.9	
	6	22.2	28.9	
Double mould-board ploughed	1	22.6	23.1	20.35±3.47
	2	22.0	23.9	
	3	22.0	15.4	
	4	22.0	18.1	
	5	22.0	22.8	
	6	22.1	18.4	

¹At 1.3 m above ground surface; termed diameter at breast height (dbh)

The responses measured during the test were:

- (i) The pore water pressure at a depth of 0.4 m below the ground surface at three locations close to the stem of the test tree,
- (ii) The horizontal displacement of the test stem at heights of 3 m and 6 m above the ground,
- (iii) The strain in the stem of the test tree at heights of 1.3 m, 2.3 m, and 3.3 m above the ground surface. The bending moments generated by the forced loading were estimated from the strain readings.

The key results from the dynamic forced loading tests are presented in Figures 2 and 3.

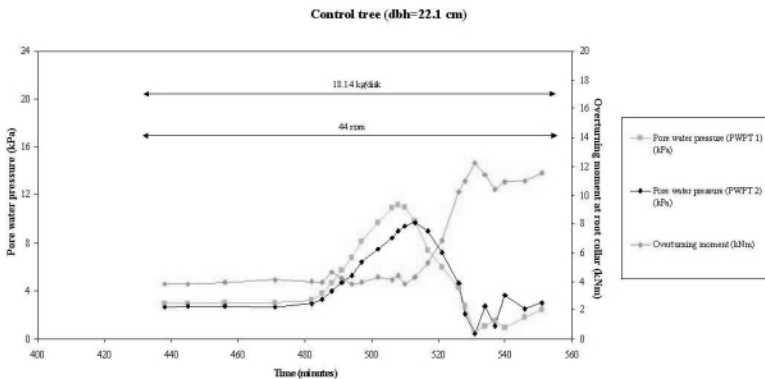

Fig. 2. Pore water pressure and overturning moment response.

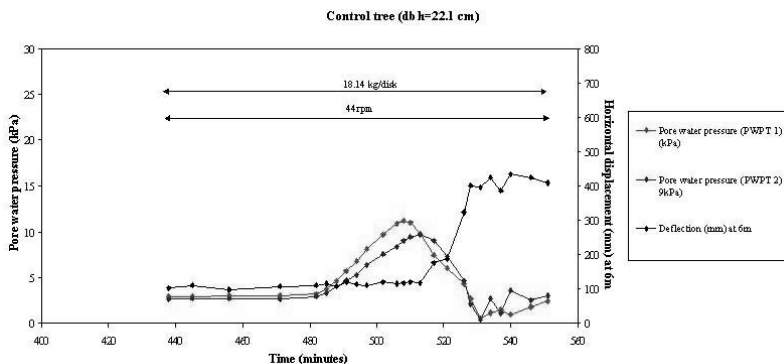

Fig. 3. Pore water pressure and horizontal displacement response.

The results clearly show that under dynamic loading substantial pore water pressures were developed in the soil beneath the rootplate of the test tree. A bending moment of approximately 4 kN m initiated the rise in pore water pressure (Figure 2). Subsequent to this rise in pore water pressure liquefied soil was noted rising to the surface at discrete locations in the rootplate. The behaviour of the test tree became increasingly erratic (this can be inferred from the displacement behaviour shown in Figure 3). The test was terminated shortly afterwards. The rise in pore water pressure that led to soil liquefaction, hydraulic fracture and an increasingly erratic stem motion was considered to be the key event that initiated failure of the tree. This finding agrees with those of Rodgers *et al.* (1995).

Previously a tree from the mole plot and the DMB plot had been subjected to similar testing. Failure was initiated in the case of the tree tested in the DMB plot, though at a higher bending moment (9.7 kN m). No such failure was initiated in the case of the tree tested in the mole plot despite a higher bending moment (14 kN m) being generated. The results for dynamic tests on these three trees are summarised in Table 2.

Results from the destructive tree pulling tests showed that the mean overturning moment required to uproot trees planted on the mole drained treatment was significantly higher ($P = 0.01$) than the overturning moment required for uprooting in the case of the double mouldboard ploughed and also significantly higher ($P = 0.05$) than that in the control plot. The mean overturning moment required for uprooting in the control plot was significantly higher ($P = 0.1$) than that for the double mouldboard plot.

Table 2: Summary of results of forced rocking (dynamic) tests

Treatment	Maximum recorded	O.M. dynamic (kPa)	O.M. monotonic (kPa)
Mole drained	1.4	14.4	33.0
DMB*	6.0	9.7	22.9
Control	8.3	4.0	24.0

*Double mouldboard ploughed

The results from the forced rocking tests provided further evidence of the benefits of using mole drains. This mode of testing initiated failure, as a result of pumping, hydraulic fracture and liquefaction, in the cases of both the double mouldboard and control treatments. In the case of the mole drained treatment no liquefaction occurred, despite a more severe loading regime having been applied.

SIMPLE SHEAR TESTING OF SOILS

Simple shear testing of soils has become increasingly popular since its inception in the nineteen fifties. The form of shearing to which specimens are subjected in these tests is similar to that which occurs in many field situations. In simple shear, a soil specimen is consolidated under one dimensional conditions and then sheared allowing for shear distortion only (Dyvik *et al*, 1987). This strain condition is referred to as simple shear strain condition. Simple shear conditions are illustrated in Figure 4.

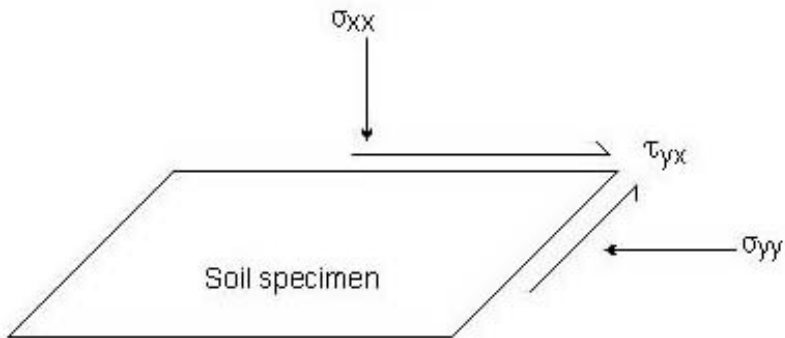

Fig. 4. Simple shear conditions (after Airey and Woods, 1987).

Potts, Dounias and Vaughan (1987) state that the deformation of a layer of soil, when the top boundary is displaced relative to the bottom layer under plain strain conditions is defined as simple shear. Conditions of simple shear occur directly beneath the stem of trees subjected to wind loading.

During the course of this study a simple shear apparatus, developed previously by Rodgers (1992) and Carey (1993), was modified and tested. The device allowed both monotonic and cyclic testing to be conducted.

Reconstituted samples of the Ballyfarnon soil were used for testing. The apparatus allowed direct measurement of pore water pressures so that truly undrained tests could be conducted. It was also possible to conduct tests of the constant vertical height type. Cyclic testing involved applying a repeated strain to a sample and recording the changes in shear stress and pore water pressure attained for each cycle. The device is illustrated in Figure 5.

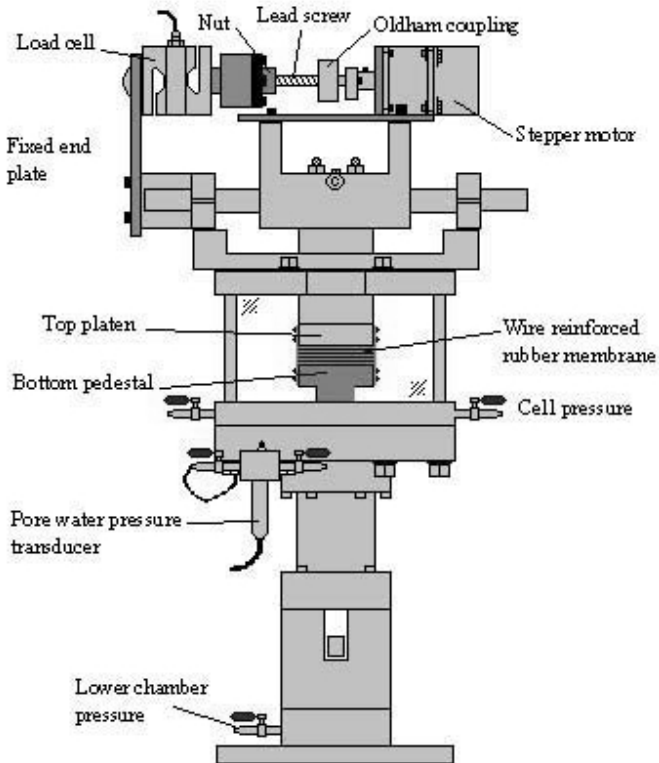

Fig. 5. Simple shear device.

Two distinct forms of simple shear were executed during the study namely monotonic tests and cyclic tests. Monotonic testing involved shearing a specimen in one direction only while monitoring the load required for shearing and the pore water pressures generated. The results allowed stress paths for the soil specimens to be obtained. Sample results from the monotonic simple shear testing are presented in Figure 6.

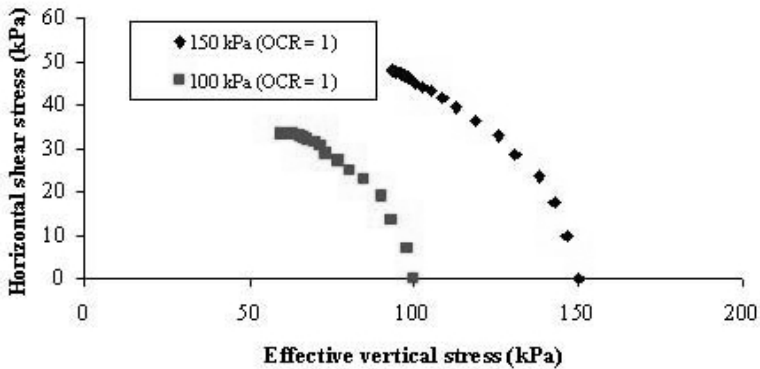

Fig. 6. Sample monotonic simple shear results.

The monotonic results gave a reference against which the results from cyclic testing could be compared. Five specimens were subjected to cyclic loading in the simple shear device at increasing levels of repeated strain. The results are summarised in Figure 7.

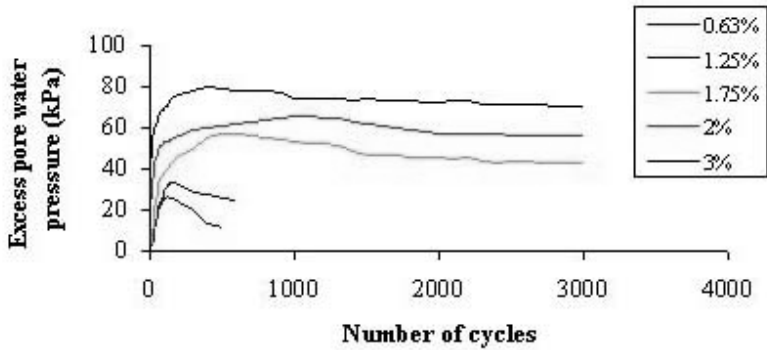

Fig. 7. Excess pore water pressure versus number of cycles.

Figure 7 shows that at each level of repeated strain substantial excess pore water pressures were generated, indicating the importance of repeated loading as a mechanism that weakens the soil.

Figure 8 shows the stress - strain graph for one of the monotonic soils consolidated to a vertical effective stress of 150 kPa. It also shows the results from the repeated loading tests for the various strain values. It is clear that there is a substantial reduction in shear stress at a given strain particularly for the target strains of 2% and 3%. This indicates that the Ballyfarnon soil can be substantially weakened by repeated loading.

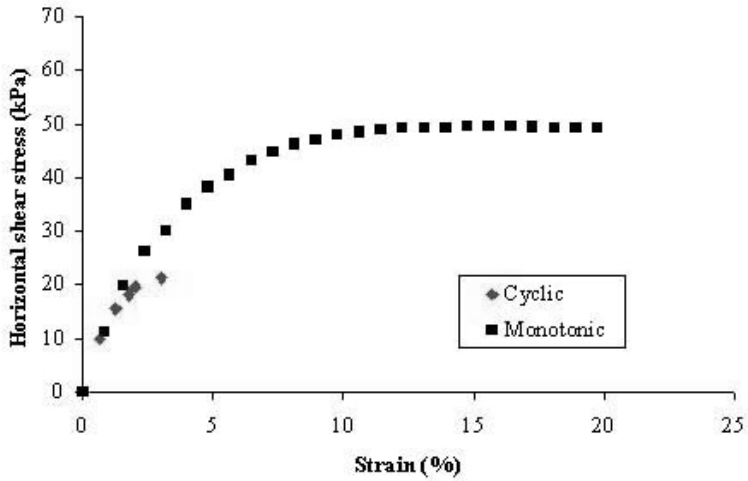

Fig. 8. Weakening of the Ballyfarnon soil as a result of cyclic loading.

Five specimens were subjected to cyclic testing under conditions of a constant vertical effective stress of 150 kPa. Cyclic loading was applied as a repeated strain. Tests were conducted at the following target strains: 0.625%, 1.25%, 1.75%, 2% and 3%. At 2% target strain the shear stress after 3000 cycles was 83% of that measured in monotonic tests. At 3% target strain the shear stress after 3000 cycles was 74% of that in monotonic tests. This indicates that there was a substantial reduction in the strength of this soil when it was subjected to dynamic loads.

COMPUTER AIDED MODELLING

The damaging effect of a high water table on tree stability has been discussed in previous chapters. The main focus of this thesis has been to identify the mechanisms by which failure of a tree, in the form of windthrow, occurs and to identify a method of drainage that can help to limit windthrow. Results presented in this thesis indicate that mole drainage could help to limit windthrow in forests. Because of this, it was decided to model the behaviour of the ground water in the mole-drained treatment.

A field experiment to compare a mole-drained plot with an uncultivated control was reported by Robinson *et al.* (1987). The experiment was established on a surface water gley at Ballinamore, Co. Leitrim in 1965. Because all relevant data from this experiment were available to the author it was decided to attempt to model the results obtained by Robinson *et al.* (1987). Finally the model results are compared with the results obtained in the field by Robinson *et al.* (1987).

A finite element-based soil-water seepage package, SEEP/W, (1991-1994) was used to model the mole drains at two spacings namely 1.025 m and 2 m. An example of the geometry of the model is shown in Figure 9. Drains at each of these spacings were modeled under both transient and steady state conditions. For the steady state analyses, three successively higher design rainfalls were applied and the steady state water table height was obtained. The height of the water table was measured at a point midway between the mole drains where the water table is nearest to the ground surface. The results from the steady state analyses are summarised in Table 3.

Table 3: Summary of results of steady state analyses

Steady state rainfall (mm/day)	Depth to water table (m)	
	1.025 m spacing	2 m spacing
5	0.400	0.225
12	0.338	0.125
30	0.225	0.000

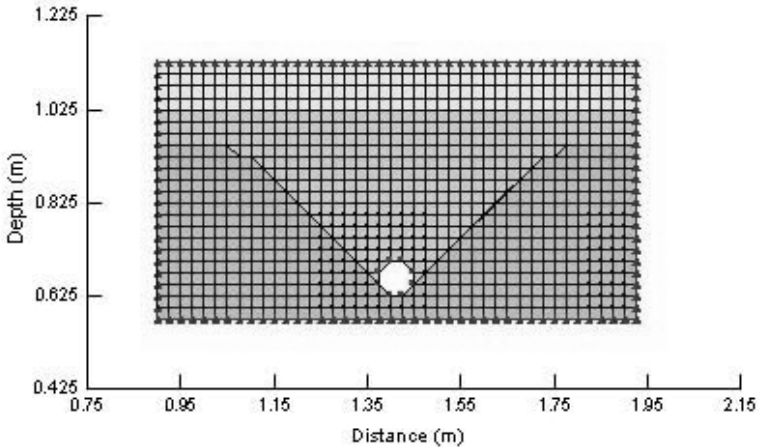

Fig. 9. Geometry of mole drain model for a 1.025 m spacing.

For the transient analyses, five days of rain as recorded at the Ballinamore experiment were applied. The water tables measured on each day for the 1.025 m spaced drain were then compared to those calculated from tensiometer results obtained in the field. The modeled and measured water tables are plotted in Figure 10.

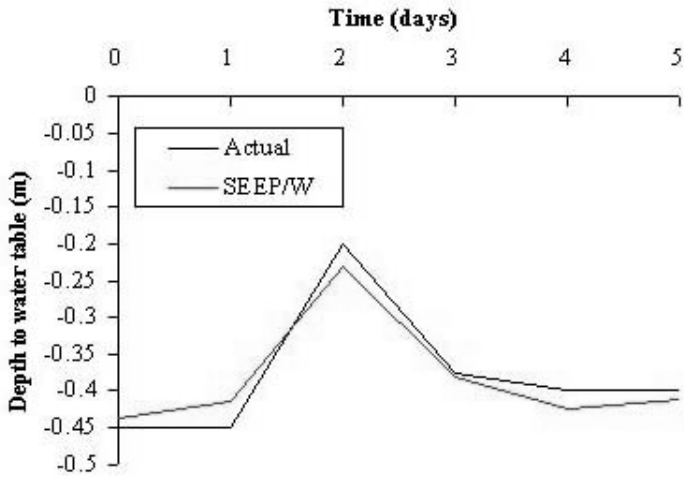

Fig. 10. Comparison of modelled and measured water tables.

The five days of rain were also applied to the drain spaced at 2 m to check the effects of drain spacing. The results of this comparison are given in Figure 11.

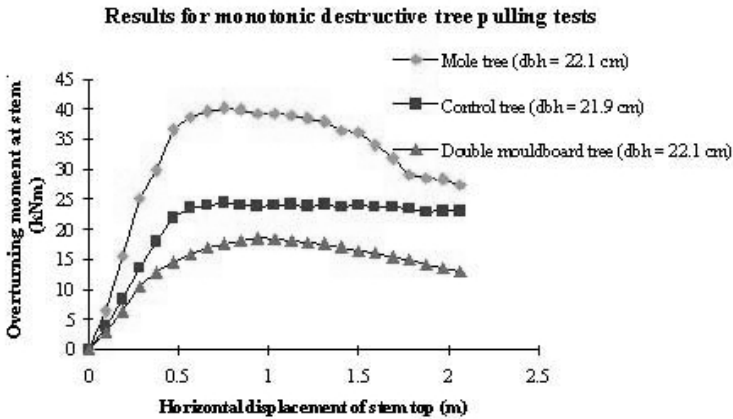

Fig. 11. Comparison of depths of water table with time for the 1.025 m and 2 m spaced drain models (water table measured midway between mole drains).

Steady state and transient analyses were performed on two models. The first comprised a mole drain separated from its neighbours by a distance of 1.025 m. The second comprised a mole drain spaced at 2 m from its neighbours. The comparison of the two under a steady state rainfall of 12 mm/day showed that the 1.025 m spaced drain maintained the water table at a depth of 0.338 m whereas the 2 m spaced drain maintained the water table at a depth of 0.125 m. The transient analysis of the 1.025 m spaced drain compared favourably with the field observations. The comparison of transient analyses conducted on the 1.025 m spaced drain and the 2 m spaced drain demonstrated the importance of close drain spacing for adequate water table control. This indicates that for forestry applications a 1 m spacing, rather than the 2 m spacing used at Ballyfarnon, should be adopted.

CONCLUSIONS

- Results from the dynamic forced rocking and destructive tree pulling tests demonstrate the improved anchorage, and therefore stability, of coniferous trees as a result of their being planted on mole drained ground.
- The simple shear apparatus worked well for both monotonic and cyclic testing. The results obtained compared well with both previous studies and with results found in the literature.
- The dynamic forced rocking test initiated failure as a result of pumping, hydraulic fracture and liquefaction of the soil in the case of the control plot. The overturning moments about the root collar of the trees which initiated the pore water pressure rises necessary to cause failure were of the order of 4 kN m. From a previous study similar failure was noted for a tree planted on double mouldboard ploughed ground at an overturning moment of 9.7 kN m. A tree tested previously in the mole plot, despite being subjected to the most severe loading regime with moments up to nearly 15 kN m, showed only a small increase in pore water pressure and no failure of the soil was noted.
- The results of the destructive tree pulling tests showed the superiority of mole drainage as a method of site preparation. The average maximum overturning moment required for uprooting in the mole plot was found to be significantly higher than that required for the dmb plot and the control plot. This difference is considered to arise from the deeper and more radically symmetric rooting system exhibited by trees in the mole plot. The average maximum overturning moment required for uprooting in the control plot was significantly higher than that

required in the case of the dmb plot. This difference is attributed to the better radial symmetry and the interlocking of the root plates of the test trees with those of their neighbours in the control plot.

- The simple shear device worked well.
- Both monotonic and cyclic simple shear test were conducted. The results showed that significant excess pore water pressures can develop in the soil when it is subjected to small repeated loads.
- Modeled results were in good agreement with the experimental data of Robinson *et al.* (1987).
- The model also provided information on the importance drain spacing in the mole plot. The model indicates that a spacing of 1 m is required for adequate drainage.
- The response of both plots to the input rainfall as determined from the modeling was very similar to that recorded experimentally by Robinson *et al.* (1987).

REFERENCES

Airey, D.W. and Wood, D.M. (1987). An evaluation of Direct Simple Shear Tests on Clay. *Geotechnique*, **37**: 25-35.

Dyvik, R., Rerre, T., Lacasse, S. and Raadim, B., (1987). Comparison of truly undrained and constant volume direct simple shear tests. *Geotechnique*, **37**: 3-10.

Robinson, M., Mulqueen, J. and Burke, W., (1987). On flows from a clay soil – seasonal changes and the effects of mole drainage. *Journal of Hydrology*, **91**: 339-350.

Rodgers, M., Casey, McMenmain, C. and Hendrick, E., (1995). An experimental investigation of the effects of dynamic loading on coniferous trees planted on wet mineral soils. Chapter 3 in *Wind and Trees* (M.P. Coutts and J. Grace Eds), Cambridge University Press, Cambridge, 204-219.

Seep, W. (1991-1994). Version 3, Geo-slope International Ltd., Calgary, Alberta, Canada.