



TEAGASC

# Research

Volume 7: Number 4, Winter 2012

ISSN 1649-8917

Research and innovation news at Teagasc [www.teagasc.ie](http://www.teagasc.ie)

## Introducing T-stór – Teagasc's new open access repository

Electricity and heat  
from biomass

Replacement heifer  
management to  
maximise performance

Productivity and income

## Contents



### 3 Editorial

The Walsh Fellowship programme

### 4 News

Researcher Profile: Dr Orla Keane  
Teagasc success in DAFM research funding call  
Communicating food science  
Teagasc launch new fertiliser tracker app

### 8 Features

8 T-Stór: Teagasc Open Access Repository  
10 Risk management in the Irish dairy sector  
12 Strengthening Teagasc's innovation culture  
13 Global alliance to strengthen agricultural research for development  
14 Everyday experimenting – Science Week at Teagasc

### 16 Food

16 Pulsed electric fields in food production

### 18 Crops, Environment and Land Use (CELU)

18 Producing electricity and heat from biomass  
20 A grand challenge – good food, clean water  
22 Cattle slurry variability: tools for improving precision of nutrient advice

### 24 Rural Economy and Development (RED)

24 Productivity and income  
26 Could 'lab grown' meat really be on the menu?

### 28 Animal and Grassland Research & Innovation (AGRI)

28 Replacement heifer management to maximise performance  
30 Expansion post 2015 – room for increasing stocking rate  
32 Liver fluke in Irish dairy herds  
34 Quality traits for recommended grasses

### 36 Events



Teagasc is a proud sponsor of Dublin City of Science 2012

Teagasc | Oak Park | Carlow



TResearch is an official science publication of Teagasc. It aims to disseminate the results of the organisation's research to a broad audience. The opinions expressed in the magazine are, however, those of the authors and cannot be construed as reflecting Teagasc's views. The Editor reserves the right to edit all copy submitted to the publication.

[www.teagasc.ie](http://www.teagasc.ie)

© Articles and images cannot be reproduced without the prior written consent of the Editor. Please note images may have been obtained from an independent source. Please quote TResearch when using direct quotes from articles.

EDITOR Catriona Boyle 059-918 3419 [catriona.boyle@teagasc.ie](mailto:catriona.boyle@teagasc.ie)  
SUBSCRIPTIONS: [alison.maloney@teagasc.ie](mailto:alison.maloney@teagasc.ie)



## The Walsh Fellowship programme

The Walsh Fellowship programme is operated by Teagasc to fund postgraduate students in Irish and international universities. Applications are made by university researchers, in collaboration with a Teagasc researcher, and generally the students spend all, or a significant proportion of their time, in the Teagasc centre, thus contributing to the Teagasc research programme. Where Teagasc receives external funding for postgraduate students, these also become part of the Walsh Fellowship programme. Typically, 50 fellowships are awarded each year, with half or more being funded from Teagasc resources.

The programme is hugely important to Teagasc for a number of reasons. It is a major contributor to the development of human capital in the agri-food sector and beyond, with most Walsh Fellows moving on to positions in industry after they graduate. It is an excellent way for Teagasc, and individual researchers, to build collaborative links with colleagues in universities in Ireland and abroad. It brings new, young researchers into the organisation and contributes to the vitality of the research programmes. It also significantly adds to the capacity of Teagasc to carry out research.

Teagasc currently has over 160 Walsh Fellows, which makes the programme a significant contributor to postgraduate education in Ireland. The majority of these are registered for PhDs. All the Irish universities and some of the Institutes of Technology are involved in the programme. At the moment, 27 are registered in universities in Northern Ireland and the UK, and a further nine in other international universities. We welcome and encourage international participation in the programme. In 2012, we initiated a scheme to facilitate a number of Walsh Fellows spending a period of up to three months in an international laboratory or research centre, and we will expand this scheme in the coming years.

Postgraduate education in Ireland is continuously evolving and developing. Teagasc will work with the universities to ensure that the educational experience of Walsh Fellows is second to none, and, in particular, that industry interaction and opportunities are enhanced. We are fortunate that the calibre of students entering the programme is excellent, and we continue to develop and improve the programme so that its reputation continues to grow.



Dr Frank O'Mara, Director of Research, Teagasc

## Clár Comhaltachta Uí Bhreathnaigh

Tá clár Chomhaltachtaí Uí Bhreathnaigh á fheidhmiú ag Teagasc chun mic léinn iarchéime in ollscoileanna Éireannacha agus idirnáisiúnta a mhaoiniú. Is iad taighdeoirí Ollscoile a dhéanann na hiarratais i gcomhar le taighdeoir Teagasc, agus go ginearálta caitheann na mic léinn a gcuid ama ar fad nó cion suntasach dá gcuid ama in ionad Teagasc, ag cur le clár taighde Teagasc dá bhrí sin. Sa chás go bhfaigheann Teagasc maoiniú seachtrach le haghaidh mic léinn iarchéime, bíonn siad ina gcuid de chlár Chomhaltachtaí Uí Bhreathnaigh chomh maith. Go ginearálta, bronntar 50 comhaltacht gach bliain, agus faigheann leath díobh siúd nó níos mó a maoiniú ó acmhainní Teagasc.

Tá an clár ríthábhachtach do Teagasc ar roinnt chúiseanna. Cuireann sé méid ollmhór le forbairt an chaipitil dhaonna san earnáil agraibhia agus thairis sin, agus faigheann an chuid is mó de Chomhaltachtaí Uí Bhreathnaigh poist sa tionscal i ndiaidh a gcéimeanna a bhaint amach. Is dóigh shármhaith é do Teagasc agus do thaighdeoirí aonair naisc chomhoibríoch a fhorbairt le comhghleacaithe in ollscoileanna in Éirinn agus thar lear. Tugann sé taighdeoirí úra, óga isteach san eagraíocht agus cuireann sé le beogacht na gclár taighde. Cuidíonn sé go mór le cumas Teagasc chun taighde a dhéanamh.

Tá os cionn 160 Comhaltacht Uí Bhreathnaigh ag Teagasc i láthair na huair, agus dá réir sin cuireann an clár méid ollmhór leis an oideachas iarchéime in Éirinn. Tá formhór na gcomhaltachtaí sin cláraithe le haghaidh PhDanna. Tá ollscoileanna na hÉireann ar fad agus cuid de na hInstitiúidí Teicneolaíochta bainteach sa chlár. Faoi láthair, tá 27 díobh cláraithe in ollscoileanna i dTuaisceart Éireann agus sa Ríocht Aontaithe. Fáiltimid agus spreagaimid rannpháirtíocht idirnáisiúnta sa chlár. In 2012, chuireamar tús le scéim chun Comhaltachtaí Uí Bhreathnaigh a éascú chun tréimhse suas le trí mhí a chaitheamh i saotharlann nó ionad taighde idirnáisiúnta, agus déanfaimid an scéim sin a leathnú sna blianta seo romhainn.

Tá an t-oideachas iarchéime in Éirinn ag teacht chun cinn agus ag forbairt i gcónaí. Oibreoidh Teagasc leis na hollscoileanna lena chinntiú go bhfaighidh Comhaltachtaí Uí Bhreathnaigh eispéireas oideachais den scoth, agus go háirithe go ndéanfar idirghníomhaíocht an tionscail agus deiseanna a threisiú. Tá an t-ádh orainn go bhfuil cailibre na mac léinn atá ag déanamh an chláir ar fheabhas, agus leanfaimid den chlár a fhorbairt agus a fheabhsú ionas go méadóidh a cháil.

An Dr Frank O'Mara, Stiúrthóir Taighde, Teagasc

### Editorial Steering Group

Miriam Atkins	Helen Grogan	Anne Kinsella	Rogier Schulte
Catrina Boyle	Tim Guinee	John Mee	Declan Troy
Eric Donald	Richard Hackett	Dermot Morris	Miriam Walsh
Niall Farrelly	Tim Keady	Edward O'Riordan	



Be social! Connect with Teagasc [http://www.teagasc.ie/news/social\\_media.asp](http://www.teagasc.ie/news/social_media.asp)

Reference to any commercial product or service is made with the understanding that no discrimination is intended and no endorsement by Teagasc is implied.

Published on behalf of Teagasc by:



IPF Media, 31 Deansgrange Road, Blackrock, Co. Dublin.  
t 01-289 3305 f 01-289 6406 [www.ipfmedia.com](http://www.ipfmedia.com)  
Design: Martin Whelan  
Editorial: Miriam Atkins

Scan with  
QR code reader



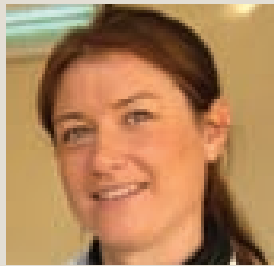

### Dr Orla Keane

Dr Orla Keane is a research scientist in Functional Genomics at Teagasc's Animal and Grassland Research & Innovation Centre, Grange. Orla joined Teagasc in 2009 as a Senior Researcher in Molecular Biology. She is interested in a range of research areas including infection biology and the role of both pathogen and host in determining the outcome of infection. Orla says: "Our aim is to identify and characterise key genes mediating this process. Pathogen genes of interest include virulence genes and genes mediating drug resistance, while host genes of interest include those that govern the host immune response to infection." Orla's interests cover a spectrum of infections including mastitis and gastrointestinal nematode infections. She also has a particular interest in sheep genetics and genomics, including identifying a major gene controlling ovulation rate in Cambridge sheep and genes controlling resistance to gastrointestinal nematodes (FP7 3SR project). "Advances in sheep genetics and genomics have typically lagged those in bovine genomics," she says. "But detailed genomic information is required to deliver a step-change in our understanding of the genetic basis underlying sustainable production and health traits."

Orla received her primary degree in Microbiology from Trinity College Dublin in 1998, and, in 1999, she followed this up with a post-graduate diploma in Statistics, also from Trinity College. In 2003, Orla completed a PhD in Microbial Genetics at Trinity. Following this, Orla travelled to New Zealand where she carried out a post-doctorate in Animal Genomics at AgResearch's Molecular Biology Unit in the University of Otago, New Zealand. The post-doctorate work involved profiling the ovine host response to infection with gastrointestinal nematodes in genetically resistant and susceptible selection lines.

In 2004, Orla was awarded the Young Researcher Award from the AMATA (Australasian Genomics Technologies Association).

Orla spent time working as a research scientist in bovine genomics with AgResearch New Zealand before returning to Ireland to complete a second post-doctorate in Evolutionary Genetics and Bioinformatics at the Genetics Department, Trinity College, in 2008.

Originally from Co Kildare, Orla is currently living in Dublin. Her personal interests include travelling, hiking, scuba diving and reading.

## Teagasc success in DAFM research funding call

The Minister for Agriculture, Food and the Marine, Simon Coveney, recently announced grant awards of approximately €32 million for 55 research projects being undertaken, on a collaborative basis, by researchers from institutions across the island of Ireland.

The awards cover a broad range of research activities relating to sustainable food production and processing, as well as forestry. Many of the projects funded are applied and pre-commercial in nature, while there is also a heavy emphasis on research involving the modern biosciences. Meat-related research features prominently, which, when taken with additional investment in dairy research, ensures that the two main parts of the sector continue to be supported to the maximum extent possible.

Teagasc will lead 30 of these projects and will participate as a partner in a further 13. Welcoming the announcement, Teagasc Director of Research, Dr Frank O'Mara, noted that this significant investment in agriculture, food and forestry research will underpin future innovation and job growth in the Irish bioeconomy. In particular, Dr O'Mara highlighted the Department of Agriculture, Food and the Marine's rigorous review process, which drives excellence in the formulation and planning of projects. He also welcomed the all-island inter-institutional collaboration, which is displayed in the funded projects. "These projects bring together the best Irish researchers from all institutions, in collaborative teams, with a focus on delivering the targets set out in Food Harvest 2020," Dr O'Mara said.

## Mastitis CostCheck Calculator

Teagasc, in conjunction with Animal Health Ireland, through the CellCheck programme, has developed the CostCheck calculator. The calculator, which was launched at the Teagasc National Dairy Conference, is designed to measure the financial losses caused by mastitis at farm level. It can be used by farmers to help understand the impact that mastitis has on profitability on their farm. The CostCheck calculator is easy to use and should be used as a catalyst to the introduction of mastitis control programmes.

The CostCheck calculator was developed based on research on the costs associated with mastitis carried out at the Teagasc Animal and Grassland Research & Innovation Centre, Moorepark, by researcher Una Geary. In her paper, presented at the Teagasc National Dairy Conference, Una estimates that reducing SCC levels from 350,000 cells/ml to 150,000 cells/ml on a 40-hectare farm with 100 cows, would increase profitability by €10,300. She demonstrated the CostCheck tool highlighting the costs associated with mastitis using data from the farmers that were in attendance at the conference.

This tool is now available on the Teagasc and Animal Health Ireland websites. For more see: <http://www.agresearch.teagasc.ie/moorepark/docs/costcheck.xls>

## Communicating food science

Teagasc recently hosted a media training seminar 'Communicating Food Science' for food researchers, in association with the EU-funded Maitre project.

Participants attended from Teagasc, University College Cork, Dublin Institute of Technology, safe food and the European Association for Food Safety.

Journalist Brooks Tigner ran the seminar, with audiovisual expertise by Ivan Picart. Participants learned about how the media works, writing press releases and got hands-on experience of radio and television interviews. Science journalist Jonathan McCrea (*The Science Squad*, RTÉ and *Future Proof*, Newstalk radio station) was the guest speaker.



**Pictured at the Maitre seminar are (clockwise from left): Dr Eimear Downey, University College Cork; Dr Kanishka Nilawerra and Dr Diarmuid Sheehan, Teagasc Food Research Centre, Moorepark; Leonard Koolman, Teagasc Walsh Fellow, Teagasc Food Research Centre, Ashtown; and Katherine Flynn, European Association for Food Safety (Safe Consortium), Belgium.**

## Low interest in farm diversification

Results from Teagasc research showed that just 2% of farmers expressed a preference for setting up a diversified farm-based business. Dr David Meredith, Teagasc, presented the results at the National Rural Development Conference in October. A nationwide sample of 472 farmers took part in the research, and when asked about their preferred development strategy, 38% said their preferred option was to develop and expand their farming business while 58% expressed a preference for combining farm work with an off-farm job.

Dr Meredith said that under the National Rural Development Programme 2007-2013 there is grant aid of €16 million available to support farm diversification

and create rural jobs. To date, there are 365 applications for projects involving €18.5 million investment and potential grant aid of €10 million. Up to the end of 2011, grant aid of almost €3 million was awarded to 113 projects. This investment has supported the creation of 116 full-time job equivalents. Dr Pat Bogue of the National Rural Network announced that the National Rural Network is commencing a research project, 'Encouraging Enterprise at Farm Level Post 2013', which will examine how farm families can be encouraged and supported to use their farm and family resources in new ways to secure their incomes. It is intended that this research will recommend measures for inclusion in the next Rural Development Programme.

## Teagasc lecture on global challenges in farming and food



**Pictured at the second in the Teagasc & RDS lecture series are (from left): Dominique van der Mensbrugghe, Senior Economist and Team Leader of the Global Perspectives Studies Team at the Food and Agriculture Organization of the United Nations (FAO); Dr Frank O'Mara, Director of Research, Teagasc; and, Leo Enright, moderator of the panel discussion.**

As part of the Teagasc & RDS lecture series, Dominique van der Mensbrugghe, Senior Economist and Team Leader of the Global Perspectives Studies Team at the Food and Agriculture Organization of the United Nations (FAO), recently delivered a lecture entitled: Will we run out of Natural resources needed for Food Production?

An article outlining the main topics of the lecture will feature in the next edition of *TResearch*. For more information on upcoming lectures in the series, visit: [www.teagasc.ie/events/rds-lecture-series/index.asp](http://www.teagasc.ie/events/rds-lecture-series/index.asp)

## Teagasc launch new willow variety guide

All information about willow varieties, which have been bred for energy purposes over the past 25 years, has been assimilated in the 'Willow Varietal Identification Guide' for the first time. The publication by Teagasc and AFBI will be of interest to willow breeders and growers worldwide.

The new Guide is available on the Teagasc website [www.teagasc.ie/publications](http://www.teagasc.ie/publications)

## Teagasc launch new fertiliser tracker app



Teagasc, in association with Vodafone Ireland, launched a new Teagasc app for use by Irish farmers and the agri industry to keep track of their fertiliser use. In turn, the app will reduce the amount of time involved in managing this process and farmers can quickly and easily use the app on the move or at the merchants store when discussing prices.

The concept of the app was the brainchild of three Teagasc advisers, Fintan Monahan, Stuart Childs and Gordon Peppard, in response to the need of their farmer clients for a tool that could help them more effectively keep track of their fertiliser purchases and usage. The three advisers received a Teagasc innovation award for the concept.

Teagasc will continuously develop and improve the app in future years. It is now available for free on the App Store for iPhone users and the Play Store for Android users.

## SFI equipment funding for Teagasc

Minister for Jobs, Enterprise and Innovation, Richard Bruton, and Minister for Research and Innovation, Sean Sherlock, recently announced the details of a €30 million investment in research infrastructure by Science Foundation Ireland (SFI), the Government's science agency. The infrastructural funding was awarded to research groups where projects demonstrated partnerships and collaborations, links with industry, relevance to Ireland's prioritised research areas and sustainable planning. A total of 37 projects were approved for funding with a total amount of €30 million.

Two Teagasc projects were among the 37 to be approved for funding. Dr Paul Cotter, who is conducting research in the Food for Health sector received support for his research project through the funding of an Ion Torrent DNA Sequencing Platform. While, Dr Kieran Meade, Teagasc, working in the area of Sustainable Food Production and Processing received funding for a BD Accuri® C6 flow cytometer.

## Global food safety: Solutions for today and tomorrow

A two-day international conference on food safety, entitled "Global food safety: Solutions for today and tomorrow", took place in Dublin in October. Jointly organised by Teagasc, in collaboration with the Institute of Food Science and Technology of Ireland (IFSTI) and the International Union of Food Science and Technology (IUFOST), the conference, and associated workshops, brought together global experts to discuss current and emerging risks to food safety. The conference addressed food safety concerns along the farm to fork chain, including chemical and microbial contaminants, and the challenges faced in managing food-borne disease internationally.

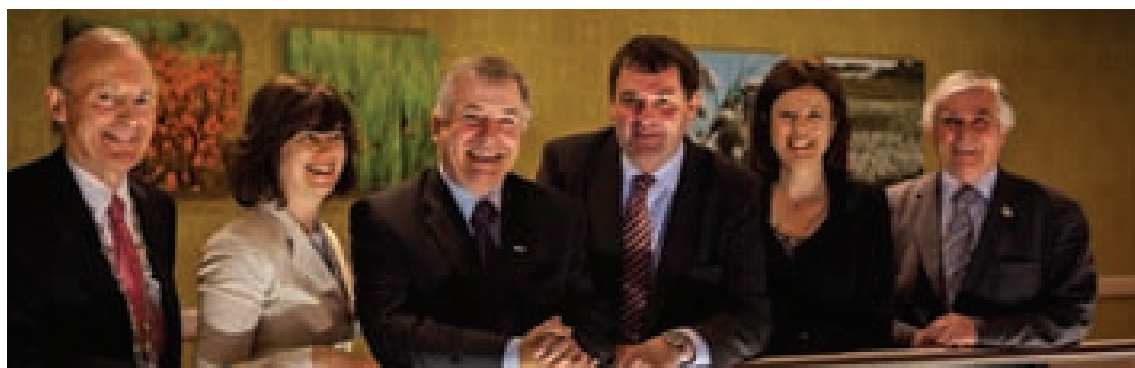

Pictured (from left): Rory Ryan, President, IFSTI; Lisa O'Connor, FSAI; Gerry Boyle, Teagasc Director, Shane McEntee, Minister of State at the Department of Agriculture, Food and the Marine; Dr Geraldine Duffy, Teagasc and Geoffrey Campbell Platt, Past President, IUFOST.

## Farm animal imaging

The Teagasc Food Research Centre, Ashtown, Dublin, recently hosted the first annual Conference of the EU COST Action FA1102: FAIM (Farm Animal Imaging Methods). The two-day event focused on carcass evaluation, meat quality, software and traceability. COST Action aims to optimise non-destructive *in vivo* and post mortem imaging and spectroscopic methods for the measurement of body composition and meat quality in the major farm animals. It will be used to devise standardised principles of carcass classification and grading across countries. FAIM will also support EU legislation on individual animal identification. FAIM comprises of a group of about 120 experts from EU and other countries and will run from 2012 until the end of 2015.

## Guild of Agricultural Journalists award



Darren Carty, *Irish Farmers Journal* (left) and Dr Michael O'Donovan, Teagasc (right) are pictured with Damien O'Reilly, RTÉ, receiving their award from the Guild of Agricultural Journalists.

Teagasc communicators fared well in the recent Guild of Agricultural Journalists Awards, which take place every two years. Darren Carty, *Irish Farmers Journal* and Dr Michael O'Donovan, Teagasc Animal and Grassland Research & Innovation Programme, Moorepark, were the winners of the Technical category for their *Grazing Guide*, which appeared in the *Irish Farmers Journal*.

Dr Noreen McHugh, Teagasc Animal and Grassland Research & Innovation Programme, Moorepark, was also nominated in the Technical category for her article 'Improving the National Breeding Programme', which featured in *TResearch*.

The Science Squad, produced by New Decade, in which Teagasc featured in three episodes, was nominated in the television category.

The members of the Judging Panel were Conor Brady, Chairman, former editor, *The Irish Times*; Frank Crosby, Professor Emeritus, UCD; Michael Fisher, former correspondent, RTÉ Belfast; Ray Ryan, former agricultural correspondent, *Irish Examiner*; and, Maol Muire Tynan, Head of Public Affairs, AIB.

## Agricultural research in Africa

Teagasc recently hosted an international workshop with an aim to build closer alignment between African national agricultural research organisations and the CGIAR (Consultative Group on International Agricultural Research) institutes. The three-day workshop, held at Teagasc Food Research Centre, Ashtown, Co Dublin, addressed issues around building closer collaboration between the research providers.

Over 60 highly prestigious delegates from Africa, the USA, Canada, Australia and the EU attended the event, which explored strategies by which agricultural productivity in Africa can be enhanced through closer collaboration between the national and international agricultural research providers. The gathering included Dr Frank Rijsberman, the newly appointed Director of CGIAR, directors of national agricultural research institutes in Africa, representative of many national donor organisations, including USAID, the EU and the World Bank.

Opening the workshop, Professor Gerry Boyle, Director of Teagasc, said that the Teagasc model of innovation support, based on the integration of research, advisory services and education could provide an excellent blueprint for developing nations struggling with the challenge of enhancing their agricultural productivity. He said this is being increasingly recognised by the growing number of international visitors to Teagasc. "In this regard, Teagasc is working with Irish Aid to send a team of experts to Tanzania to see how it could assist in building the Teagasc model of innovation in that country," said Professor Boyle.

## Teagasc launches new technology updates



Teagasc has launched a collection of over 100 Technology Updates, highlighting the key findings from its research over the last five years. The Teagasc Technology Updates cover three of the four Teagasc research programmes: Animal and Grassland, Research & Innovation Programme; Crops, Environment and Land Use Programme; and, Rural Economy and Development Programme.

Teagasc Technology Updates 2007-2012 can be viewed on the publications section of the Teagasc website at: [www.teagasc.ie/publications](http://www.teagasc.ie/publications)

**Pictured at the launch were (from left): Professor Gerry Boyle, Teagasc Director; Jane Kavanagh, Teagasc Programme Implementation Co-Ordinator; and, Dr Noel Cawley, Teagasc Chairman.**

## New initiative to generate jobs for rural Ireland



**Pictured at the launch of CEDRA are (from left): Professor Cathal O'Donoghue, Head, Teagasc Rural Economy and Development Programme; Pat Spillane, Chairman of the Commission; Phil Hogan, Minister for the Environment, Community and Local Government; and, Finola Moylette, Department of the Environment, Community and Local Government.**

Dr Cathal O'Donoghue has been appointed Head of the Executive of the newly-established Commission for the Economic Development of Rural Areas (CEDRA).

Teagasc is facilitating the organisation and research of the Commission.

Commenting on his lead research role, Dr Cathal O'Donoghue said: "Teagasc and I are honoured to be able to support the Commission. We, in Teagasc, have previous experience in providing research support to the Food Harvest 2020 Committee that developed the Agri-Food Strategy. Together, with our partners, we

will provide whatever support we can to facilitate the mission of the Commission. The work of the Commission is particularly relevant for our stakeholders as farm households have been particularly affected by the down turn, with the off-farm employment rate of farmers falling back to late 1990s levels. On the other hand, the Food Harvest 2020 strategy for the agri-food sector has a target to generate 25,000 new jobs and thus the sector can make a substantial impact on rural job creation."

The focus of the Commission's work will be on 'outside the farm gate' dimensions of economic development.

## Health claims for functional foods

At a University College Cork Symposium, international experts offered guidance to industry on making health claims for functional foods, including a 'how-to' approach to carrying out human dietary interventions. Professor Paul Ross, APC and Teagasc presented case studies of companies that have conducted trials to validate health claims for functional foods.

An overview of the GMP Facility, UCC and MTL, Teagasc, Moorepark was provided by Professor Gerald Fitzgerald, UCC and Professor Paul Ross, Teagasc. Supports available to small and medium enterprises from Enterprise Ireland, University College Cork, Teagasc and Atlantia Food Clinical Research Organisation, a new independent commercial Clinical Research Organisation that designs and conducts human intervention studies, were also outlined. The Symposium was organised by University College Cork in partnership with the Alimentary Pharmabiotic Centre, Eldermet, Enterprise Ireland, Atlantia Food CRO, Teagasc and The Food Industry Training Unit, UCC.

# T-Stór: Teagasc Open Access Repository

Teagasc's Head Librarian introduces Teagasc's newly developed open access repository, which makes Teagasc research freely available online.

Over the past few months, various reports have been published on the topic of open access. These include the Finch Group report ('Working Group on Expanding Access to Published Research Findings', 2012), the 'Publishing and the Ecology of European Research' (PEER) final report (Wallace, 2012), the European Research Council announcement of its new open access policy (ERC, 2012) and the European Commission's launch of a communication and recommendations to Member States 'Towards better access to scientific information' (EC, 2012). Science Europe recognised open access as a priority area in which a common policy and action plan will be developed and implemented. The UK has made a clear commitment to ensuring that all publicly-funded research papers will be freely available (Department for Business, Innovation and Skills, 2011). On October 23, Minister Sean Sherlock launched the Irish National Principles for Open Access (Sherlock, 2012), which have been signed by most bodies involved in funding or conducting research in Ireland.

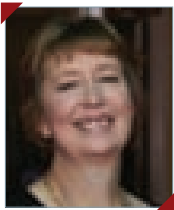

**Maire Caffrey,**

Head Librarian, Teagasc,  
Ashtown Food Research  
Centre, Dublin 15.

Correspondence:  
maire.caffrey@teagasc.ie

## What is Open Access?

In the context of scientific research dissemination, Open Access (OA) refers to the free availability on the internet of scholarly articles published in an electronic format, permitting any user to read and re-use the content, provided that the author is properly acknowledged and cited. The Budapest Open Access Initiative of 2002 gave a generally accepted definition (Open Society Institute, 2002).

For many years, the main method of dissemination of scientific results has been through publication of articles in scientific journals. It was only possible

to read the published journal articles if you paid a subscription to the journal.

Supporters of OA believe that if research articles were freely accessible, the usage, impact, productivity and progress of research would be maximised. There has also been a rise in support for the idea that results of publicly-funded research should be freely available, in order to maximise its impact and value-for-money.

The peer-review process is essential to guarantee the integrity of the research results being reported. OA is entirely compatible with peer review and all the major OA initiatives for scientific and scholarly literature insist on its importance. OA literature is not free to produce; however, the question is not whether scholarly literature can be made costless, but whether there are better ways to pay the bills than by charging readers and creating access barriers. Business models depend on how OA is delivered, as outlined by Suber (2004).

There are two primary vehicles for delivering OA to research articles:

- OA journals perform peer review and then make the approved contents freely available to the world. OA journals pay their bills by charging the authors (or their employers or funders) upfront so that access can be free of charge for everyone with internet access. This is known as "Gold Open Access".
- OA repositories do not perform peer review but simply make their contents freely available to the world. Open Access repositories are digital collections of articles that have been placed there by their authors. Subject to copyright, authors can deposit copies of their finished articles in repositories alongside their publication in normal journals. When repositories comply with the metadata harvesting protocol of the Open Archives Initiative, users can find their contents without knowing which archives exist, where they are



located or what they contain.

Of course, repositories can contain other types of documents as well as journal articles, and Teagasc will consider how T-Stór can store other types of publications in a way that complements its publications page.

### Repository development

All the Irish universities have set up repositories, as have several other relevant bodies, such as the Health Service Executive, Royal College of Surgeons, Dublin Institute of Technology, Waterford Institute of Technology and the Marine Institute. Irish universities received Government funding to develop a federated harvesting and discovery service via a national portal. This portal is called RIAN and is accessible at [www.rian.ie](http://www.rian.ie)

A number of research funders now have rules in place that make deposits in an open access repository a requirement of any grant. Other funders make a strong recommendation for deposit. From 2014, any projects funded by the EU Horizon 2020 programme will have to make resulting articles available on open access. Science Foundation Ireland also mandates open access.

The various journal publishers now generally agree to the deposit of some version of the article in such an Institutional Repository – usually the post-print version, which has been through the refereeing process.

### T-Stór

This is the background to Teagasc's decision to set up a repository for dissemination of our publications. Aside from the benefits to the user, there are many additional benefits to Teagasc from having such a repository:

- It will increase the visibility and impact of Teagasc outputs.
- There is accumulating evidence that shows that research articles that have been deposited in Open Access repositories are cited more often than those that have not.
- Usage will be measurable.
- As well as copies of published articles, T-Stór can be developed to include many different types of Teagasc publications. The software used makes the metadata searchable by internet search engines and would contribute to making publications more visible.
- It will provide for permanent archiving and preservation of Teagasc research outputs and other publications.
- Once Teagasc authors have deposited their work in T-Stór, they will be able to use links to the repository to enhance their profile on the Teagasc website and social media.

Setting up a Teagasc repository was a priority project for the Teagasc Library Service and ICT department for 2012. After consideration of the various options, the ICT department decided that this should be set up and hosted externally and we invited some companies to tender earlier this year. Central Solutions, based in Limerick, was awarded the contract. Work commenced in April of this year and T-Stór went live in August. Already, there are over 100 publications available in T-Stór, although it will take some time to add historical content.

### Searching T-Stór

Anyone can access T-Stór online at: <http://t-stor.teagasc.ie> and search or browse the content. For ease of use, the documents are organised into high-level categories based on the four Teagasc

Programme areas: Animal and Grassland Research & Innovation Programme; Crops, Environment & Land Use Programme; Food Programme; and, Rural Economy & Development Programme. Each of these is subdivided into collections corresponding to Teagasc research departments. There is also a category for Teagasc's peer reviewed journal the *Irish Journal of Agricultural and Food Research* and there will be further categories as content is added.

Users can also browse by author, title, subject or issue date. There are basic and advanced search facilities, which work in a similar way to searching any other website or database. If any user wishes to receive automatic RSS updates when new items are added to any collection, they can register for this, using their email and a self-selected password (using the My T-Stór function).

### Irish National Principles for Open Access

Earlier this year, a meeting of interested bodies was convened by Science Foundation Ireland and the Health Research Board to discuss the existing approach to Open Access (OA) for publicly-funded research publications in Ireland, and to consider the possibilities for building a common OA approach. The group concluded that they could usefully co-operate in this area to further OA development nationally. They have now adopted the title of the National Steering Committee on Open Access Policy.

The first achievement of this group has been the National Principles for Open Access Policy Statement (National Steering Committee on Open Access Policy, 2012).

The National Steering Committee is committed to continuing work to implement the Principles and develop the national infrastructure for open access. Teagasc fully supports the National Principles and will continue cooperation with the other supporting organisations.

### References

- Department for Business, Innovation and Skills.** 2011. Innovation and Research Strategy for Growth. London: Department for Business, Innovation and Skills, UK.
- EC.** 2012. Towards better access to scientific information: Boosting the benefits of public investments in research. European Commission.
- ERC.** 2012. *European Research Council renews its commitment to open access by joining Europe PubMed Central* Available online: [http://erc.europa.eu/sites/default/files/press\\_release/files/EuropePMC\\_press\\_release\\_WT\\_ERC\\_FINAL.pdf](http://erc.europa.eu/sites/default/files/press_release/files/EuropePMC_press_release_WT_ERC_FINAL.pdf)
- National Steering Committee on Open Access Policy.** 2012. National Principles for Open Access Policy Statement. Available online: [www.hea.ie/files/OpenAccessPolicyStatement.pdf](http://www.hea.ie/files/OpenAccessPolicyStatement.pdf)
- Open Society Institute.** 2002. *Budapest Open Access Initiative* Available online: [www.opensocietyfoundations.org/openaccess/read](http://www.opensocietyfoundations.org/openaccess/read)
- Sherlock, S.** 2012. *Seán Sherlock, TD Speaking at the Digital Repository of Ireland* Available online: [www.labour.ie/seansherlock/blogarchive/2012/10/26/sen-sherlock-td-speaking-at-the-digital-repository-of-ireland-dri-event/](http://www.labour.ie/seansherlock/blogarchive/2012/10/26/sen-sherlock-td-speaking-at-the-digital-repository-of-ireland-dri-event/)
- Suber, P.** 2004. *A Very Brief Introduction to Open Access* Available online: [www.earlham.edu/~peters/fos/brief.htm](http://www.earlham.edu/~peters/fos/brief.htm)
- Wallace, J.** 2012. ECP-2007-DILI-537003 PEER Final Report. Publishing and the Ecology of European Research.
- Working Group on Expanding Access to Published Research Findings ('Finch Group').** 2012. Accessibility, sustainability, excellence: how to expand access to research publications.



# Risk management in the Irish dairy sector

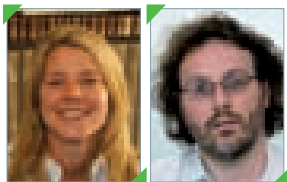

A recent conference discussed price volatility and risk management in the Irish dairy sector, the main highlights are summarised below.

the extreme price volatility that the dairy industry faces. Reflecting this concern Teagasc, Cork Institute of Technology (CIT) and the Irish Cooperative Organisation Society (ICOS) recently organised a one-day conference for about 60 dairy executives and other interested parties from around Ireland. The event included contributions from researchers, risk industry professionals and the dairy industry. Some of the key issues discussed are summarised below.

## Milk price volatility

There are particular reasons for the Irish dairy sector to be concerned about price volatility. The first is the planned expansion in milk production once milk quotas are removed and the second is high reliance of the Irish dairy industry on export markets. The seasonality of Irish milk production and the resulting commodity focus of the dairy processing industry means that much of Irish production is concentrated in four to five months of the year, making market returns, milk prices and dairy farm incomes vulnerable to even short term price fluctuations.

Prices are important. Prices can rise and fall to the alternating delight and disappointment of consumers and producers. However, you might be surprised to learn that economists do not always see price volatility as a bad thing. In fact it's an essential signal to producers and consumers of goods that determines the amount that is produced and consumed. However, since 2007, EU and world dairy markets have been in a cycle of extreme price volatility. This extreme volatility has been mirrored at farm level where milk producers have seen monthly per litre milk prices in excess of 40 cent and as low as 20 cent over the last few years (see Figure 1). Extreme price volatility is a serious business problem affecting profitability, cashflow and investment decisions of farms and milk processors.

There is a growing desire to limit exposure to

**Trevor Donnellan,**  
**Dr Kevin Hanrahan** and **Dr Thia Hennessy**, Principal Research Officers, Agricultural Economics and Farm Surveys Department, Teagasc  
**Dr Declan O'Connor**, Department of Mathematics, Cork Institute of Technology  
**Dr Michael Keane**, Department of Food Business and Development, University College Cork  
**Dr Eoin Kelly**, Department of Mathematics, Cork Institute of Technology  
 Correspondence: trevor.donnellan@teagasc.ie

### Milk producers and milk processors

There are knock-on consequences of price volatility for farm incomes. But the negative effects of price volatility extend beyond farmers' incomes, affecting cashflow, capacity to secure financing for investment and farmers' ability to fund the repayment of financing. Price volatility also creates business problems for milk purchasers and processors and in a post-milk quota environment could create uncertainty in terms of the volume of milk supplied by farmers. Processors facing volatile farm gate milk prices also face challenges in correctly pricing dairy products during contract negotiations with their own dairy commodity customers. This uncertainty can have an impact on business profitability and the ability of processors to fund expansion plans.

### Policy tools to address risk

Policy tools may be able to counter extreme price volatility. In the context of the Common Agricultural Policy (CAP), the role of the Single Farm Payment as an income volatility buffer at farm-level must be acknowledged. CAP reform could be used as an opportunity to introduce enhanced measures to address excessive price volatility. However, any new tools designed to manage price volatility through the CAP will need to be funded out of, at best, a fixed CAP budget and in all likelihood, such funding would have to be diverted from existing policy schemes.

In the USA, price volatility increased significantly in the late 1980s as a result of reduced price supports. So from an EU perspective, it is instructive to look at how the USA has dealt with extreme milk price volatility. For some years, the USA dairy industry has, with mixed success, been using a combination of public and private risk management tools to counter price volatility. The search for appropriate instruments for the USA market continues in the current USA Farm Bill deliberations, which are set to run into the first quarter of 2013.

### Risk management through financial instruments

In the USA, dairy futures markets exist but, with the exception of USA class III milk contracts, these dairy futures are thinly traded. By contrast, the use of such financial products in the EU dairy sector is in its infancy. In the EU, in order to get others (in particular speculators who do not have a physical need to hedge) to share or assume some of the risk faced by farmers and milk processors, there will be a growing requirement for public access, on a timely basis, to accurate key dairy market price and quantity data. These data quality criteria are currently met in the USA but not in the EU.

### Forward milk and input pricing

There is a need to develop milk producers' understanding of the concept of forward pricing of milk (and inputs). Some Irish dairy processors argue strongly that there are benefits to farmers from locking in a portion of their milk price, as well as, if possible, a portion of their input costs. However, while research has shown that there are tangible benefits to processors in locking in prices for milk, the USA experience indicates that the benefits to milk producers are not always as clear cut. In the context of volatile milk prices, farmers need more than just milk/input price certainty. Farmers also desire a price that returns a profit each year.

Given their position as price takers, farmers cannot use these tools to lock in a price that guarantees a profit every year. However, forward pricing can often provide peace of mind by reducing, though not eliminating, the likelihood of producers experiencing an income crisis in a given year.



Figure 1: Irish Monthly Farm Milk prices 2005 to 2012.

### Milk pricing index

Dairy industry commentators have observed that in recent years, Irish dairy processors have been forced to engage in a form of ineffective milk price smoothing. Cash reserves are used to hold prices at elevated levels when commodity markets begin to take a downturn, rather than using such reserves to boost prices when commodity markets are at their weakest. However, this entails making provisions for the inevitable rainy day when dairy product markets are buoyant.

There is merit in developing a transparent, objective and fair milk pricing tool, common to all Irish milk purchasers. Such an index would clearly identify to farmers and processors the commercial value of milk at all times in the price cycle. This would allow producers and purchasers to develop tools to stabilise incomes through, for example, a system of countercyclical milk payments (payments that would be triggered in periods of low market prices). Such payments could be funded through deductions from price peaks, as well as via possible CAP Pillar II supports. Such a milk pricing tool would also facilitate the development of derivatives-based tools, as such tools depend on objective pricing structures (like the Chicago Mercantile Exchange) to close out contracts.

### The role of education

With the increased prevalence of volatile prices and the emergence of risk management as a business objective at both the processor and producer level, the relative novelty of risk management tools at the farm and processor levels means that there is a requirement for a programme of education for stakeholders across the dairy industry.

Volatile agricultural prices are a consequence of policy reform and the integration of European and global agricultural commodity markets. Irish farmers and the Irish agri-food industry will increasingly need to plan for an existence characterised by such volatility. Public policy and risk management instruments such as forward contracting, futures and derivatives contracts all have a potential role to play in enhancing the agri-food sector's ability to mitigate the impact of risk.

Education in relation to the use of risk mitigation strategies as well as the development and dissemination of timely high quality market information, including transparent milk pricing indices, will be important to the future of the Irish dairy industry.

Innovation

# Strengthening Teagasc's innovation culture

Innovation in the public sector, particularly in policy development, programme design and service delivery, is a necessary element in public services becoming better targeted, more responsive to needs and more efficient, explains Dr Lance O'Brien.

The study and practice of innovation have traditionally been associated with the private sector, where the pressure to effectively innovate is significant, since successful innovation equates to organisational survival and strength. The primary motivators to innovate for commercial firms are to maintain or increase profits and thus to survive in a highly competitive global economy.

In contrast, innovation in public service organisations has not historically featured as a crucial determinant of survival, no doubt due to the fact that, compared to the private sector, these operate under different pressures, interests, restrictions and demands. Up to recently, the incentive to innovate for public sector bodies, in general, had been low and the risk associated with innovation high.

## Enhancement of public sector performance

In more recent times there has been a growing realisation that innovation should become a more important strategy of the public sector to enable it to respond better to a rapidly changing environment and citizen/business expectations. The impact of the global downturn has led many governments to prioritise the enhancement of public sector performance. Innovation in the public sector, particularly in policy development, programme design and service delivery, is a necessary element in public services becoming better targeted, more responsive to needs and more efficient.

Given its specific mandate, Teagasc has historically devoted more attention to innovation than is the norm for public sector organisations, although it was not always explicitly stated in those terms. However, with the launch of the 'Teagasc 2030 Foresight' report in 2008, the organisation specifically committed itself to the development of a strong internal culture of innovation as the basis for delivering on its mission of "supporting science-based innovation in the agri-food sector and wider bioeconomy so as to underpin their profitability, competitiveness and sustainability".

## Innovation in Teagasc

To realise this vision, the 'Foresight' report argued that Teagasc itself had to become more innovative as an organisation by: ensuring the continued upgrading of its scientific capabilities; integrating research, advisory and education services so as to transfer knowledge more effectively; promoting more focused stakeholder participation; strengthening priority setting; and developing more flexible resource allocation mechanisms.

Over the past four years, the organisation has taken major strides in becoming more innovative and flexible in delivering the necessary programmes to enable the sector address growing opportunities in the global marketplace and counter unprecedented challenges. Innovation is essential in driving the needed transformation of the sector. Producing food requires skills and knowledge, as well as technology – not only the traditional skills that have always been associated with crop and livestock production but, increasingly, the technical and economic expertise required to capitalise on scientific advances and to operate within the modern food system. This involves a total commitment to sustainable, cost-competitive production while seeking to extract greater value from products through improved efficiency, better alignment of production with global market needs and by positioning the country as a global leader in the production of environmentally sustainable, safe and ethically-produced products.

## Strengthening innovaton culture

In both agriculture and food research, we are pursuing the exciting opportunities presented by the exploitation of the biosciences. These include accelerated animal and crop breeding programmes and the development of functional foods in support of the national policy on foreign direct investment. In rural development, we prioritise on-farm and off-farm diversification to combat the much-reduced employment opportunities that are likely to prevail off-farm. Above all, we are committed to ensuring that we strengthen our knowledge transfer function in both agriculture and food.

Teagasc intends to continue to strengthen its own internal innovative culture in order to foster innovation in the sector by ensuring that farmers and food companies are not only made aware of new knowledge and technology, but are encouraged and facilitated to exploit the opportunities that are presented by these developments, thereby contributing to the Government's targets, as set out in Food Harvest 2020, for increased output, value and exports and sustainable jobs in the sector.



**Dr Lance O'Brien**

Foresight and  
Strategy Manager  
Teagasc Head Office,  
Oak Park, Carlow  
Correspondence:  
lance.obrien@teagasc.ie

# Global alliance to strengthen agricultural research for development

Feature

Dr Lance O'Brien reports on the Second Global Conference on Agricultural Research for Development.

The second Global Conference on Agricultural Research for Development (GCARD2) took place in Punta del Este, Uruguay, from October 29 to November 1. The conference was attended by over 800 delegates from 101 countries, with a further 1,000 joining the event on-line.

GCARD is a unique face-to-face forum for integrating diverse viewpoints, including those of smallholder farmers. It reaches out to everyone, from young agricultural researchers to senior policy leaders and from local organisations to global ones. The aim is not to produce one universally applicable answer, but to build better understanding of the implications of different agricultural choices for a broad spectrum of sectors.

The first GCARD (GCARD1), which was held in Montpellier in 2010, produced a landmark roadmap containing a set of key principles for transforming and strengthening agricultural research for development systems at national, regional and international level. GCARD2 focused on implementing the principles for action identified in the roadmap. In recognition of the crucial role that some 500 million smallholder farmers will play in providing the necessary increased food production for a population of over nine billion in 2050, the theme for GCARD2 was 'Foresight and partnership for innovation and impact on smallholder livelihoods'.

## Foresight

The challenges we face for agricultural development, for global food security, and for the health of our planet are difficult and complex, and have the potential to change dramatically over time. We cannot restrict ourselves to addressing the present day issues. Rather, we must act now and align funding and policy discussions with future challenges and opportunities. It is important that funding decisions are sustainable to deliver the long-term research that will create a food secure future.

In light of this, GCARD2 emphasised the need for better foresight in guiding agricultural research for development investments and processes. Building better foresight will require practitioners and users to bring together diverse approaches to understanding our future needs. Better foresight must also be built around the many different stakeholders contributing to foresight: involving different regions, young people, small farmers and, in particular, women farmers, and it must progressively develop foresight capacities as users (awareness) and doers (practical know-how and knowledge). These aims can best be achieved through the Global Foresight Hub, which was established

following GCARD1, in order to bring together foresight practitioners from around the world, create long-term regional capacity in foresight and engage policy makers to better inform their decision-making.

## Partnership and capacity building

A second major theme of the conference was partnership and capacity building. The conference agreed that partnership and collective focus between institutions of all forms are essential to ensuring effective pathways to impact. The GCARD2 process set out an agenda for change and has begun to mobilise the partnerships and commitments required to deliver this around some of the major challenges of today and tomorrow, including a number of key agendas such as gender, nutrition and protracted crises that have received very little attention in the past. It was also recognised that effective partnership requires capacities, knowledge sharing and collective actions at all levels. In particular, the GCARD endorsed the need to strengthen extension services in order to ensure that research results reach farmers and are used by them to raise productivity and enhance sustainability. The concept of 'The New Extensionist' was put forward, examining the roles, strategies and capacities needed in extension services to meet the challenges of global hunger.

## Shaping the future

The world faces a major challenge in ensuring sufficient food for a growing population in the face of rising incomes and an increase in resource-intensive western-style diets. The GCARD process aims to address this challenge in a coordinated manner by involving all of the key stakeholders. It is important that Ireland is part of this ongoing process, including the global Foresight initiative. The message from GCARD2 is that there are grounds for optimism. We can feed the world, but we need to focus urgently and specifically on food security, encourage political and other leaders to introduce the right policies, invest in research and development and ensure that these actions reach the farmers who need them most.

## Further reading and online resources

Global Conference on Agricultural Research for Development 2012: [www.egfar.org/gcard-2012](http://www.egfar.org/gcard-2012)

The GCARD Road Map - Transforming Agricultural Research for Development Systems for Global Impact: [www.fao.org/docs/eims/upload/294891/GCARD%20Road%20Map.pdf](http://www.fao.org/docs/eims/upload/294891/GCARD%20Road%20Map.pdf)

Global Foresight Hub: [www.egfar.org/our-work/shaping-future-together/global-foresight-hub](http://www.egfar.org/our-work/shaping-future-together/global-foresight-hub)

The 'New Extensionist': Roles, Strategies, and Capacities to Reduce Hunger and Poverty: [www.g-fras.org/en/157-the-new-extensionist](http://www.g-fras.org/en/157-the-new-extensionist)



**Dr Lance O'Brien**

Foresight and Strategy Manager  
Teagasc Head Office,  
Oak Park, Carlow  
Correspondence:  
[lance.obrien@teagasc.ie](mailto:lance.obrien@teagasc.ie)

# Everyday Experimenting - Science Week at Teagasc

'How clean are your hands? Demystifying DNA. Reducing greenhouse gas emissions.' These are some of the many topics that over 1,000 second-level students got the opportunity to investigate, while also participating in many hands-on experiments, at Teagasc's Science Week events around the country this November.

The aim of Science Week is to promote the relevance of science, technology, engineering and maths in our everyday lives and to demonstrate their importance to the future development of Irish society and to the economy.

Science Week is a Discover Science & Engineering (DSE) project. DSE initiatives are managed by Science Foundation Ireland on behalf of the Office of Science, Technology and Innovation at the Department of Jobs, Enterprise and Innovation.

In Carlow, Dr Stephen Kildea, Teagasc Crops, Environment and Land Use Research Centre, Oak Park gave a talk entitled 'Potatoes get sick too' to primary-level students from Gaelscoil Eoghain Ui Thuairisc at Carlow library as part of the library's Science Week speaker series.

In Cork, students visiting Teagasc Moorepark heard how probiotic bacteria work to fight off bad bacteria and how examining their DNA helps. They saw how cream is separated and butter and buttermilk are made. Students checked milk samples for mastitis using somatic cell counts. They also got to see how drafting gates work in a milking parlour and how they can help farmers manage large numbers of animals. Students learned about ruminant nutrition, methane emissions, automation in milking, the importance of grassland measurement and management, and calf rearing.

In Dublin, UV light detectors were used to check just how clean hands are and the importance of good hand washing was stressed at the Food Safety Department, Teagasc Food Research Centre, Ashtown. 'Fungi: the good, the bad and the weird!' was presented by the Horticultural Development Unit, and students got a chance to grow their own fungal zoo. Students performed sensory analysis on foods and they also took part in a focus group to come up with advice for our policy makers with the Food Marketing Unit. In the Food Biosciences Department,



**Catriona Boyle**  
Science Writer/Editor,  
Research Directorate,  
Teagasc Head Office, Oak  
Park, Co Carlow.  
Correspondence:  
catriona.boyle@teagasc.ie



Leaving Certificate Students Erica Mellotte, Emma Elwood and Abby Dempsey from Taylor's Hill Dominican College at Teagasc in Athenry.



Students from Lutterellstown Community College visiting Teagasc Food Research Centre, Ashtown, learn about sensory analysis from Carmel Farrell, who is involved with the sensory analysis programme under the brief of Innovation and Product Development support for SMEs and new food businesses.



Researcher Noel McCarthy showing students how pasteurisation and homogenisation are used to kill microbes in the manufacture of milk infant formula.



The winners of the Walsh Fellowships seminar are pictured (from left): Ciara McDonnell, Noelle O'Riordan, Tom Cannon (Chairman of the Agricultural and Rural Affairs Committee, RDS), Declan Troy, Assistant Director of Research, Teagasc, Noeleen McDonald, Rory Ryan (Institute of Food Science and Technology of Ireland President) and Nora O'Shea.



Dr Sinead Waters, Senior Researcher, with Students from Eureka Secondary School, Kells, at Teagasc Grange.

students learned that the marine environment is a rich source of plants and animals and the biodiversity of plants and animals found in the Irish seas is great, and thus holds great potential for the development of marine-origin functional foods.

In Galway, students visiting Teagasc Athenry carried out a series of practical experiments and students got to see how science is being used to address issues related to reproduction and parasitism in sheep – specifically methods for investigating parasite infection and resistance to anthelmintics. Alternative sheep breeds were on view and students learned about their attributes and role in Irish farming. A grassland demonstration examined different grass and clover species and how nitrogen fixation works, as well as dealing with environmental issues and the use of slurry and fertilizer.

In Meath, students visiting the Teagasc Animal Bioscience Research Centre, Grange, got to see the latest technologies in molecular biology in the areas of animal breeding, fertility, reproduction and health and welfare.

In Wexford, students visited field experiments at Teagasc Crops Environment and Land Use Research Centre at Johnstown Castle. They learned about current Teagasc research in the areas of ecology, carbon cycling, water quality and soils, and nutrient efficiency.

### Teagasc Walsh Fellowships seminar

At the 17th annual Teagasc Walsh Fellowship Seminar 2012 in the RDS, Dublin, 18 young researchers presented the results of their research, with a further 21 postgraduate students publishing posters.

The overall winner and Walsh Fellow of the year was Noeleen McDonald for her paper on 'Utilising the soil's nitrogen supply potential for efficient grass production'. She was presented with the RDS medal.

Other winners were:

- Best presentation on Food, Ciara McDonnell, Teagasc Food Programme, Ashtown and UCD
- Best three-minute presentation, Noelle O' Riordan, Teagasc Food Programme, Moorepark and NUI Galway
- Best poster, Nora O'Shea, Teagasc Food Programme, Ashtown, and UCC

Dr Frank O'Mara, Director of Research, Teagasc said: "The Walsh Fellowships Programme is a critically important component of Teagasc's Research and Knowledge Transfer programmes. Teagasc currently has over 160 Walsh Fellows, which makes the programme a significant contributor to postgraduate education in Ireland. The majority of these are registered for PhDs. All the Irish universities and some of the Institutes of Technology are involved in the programme. At the moment, 27 are registered in universities in Northern Ireland and the UK, and a further nine in other international universities."

This year saw the first full year of the new MAgrSc Innovation Support Programme, which is being run in association with University College Dublin. This programme aims to equip graduates with the skills and knowledge to be effective in building the capacity of farmers to adopt new practices and technologies. The Walsh Fellowship Programme has proved to be effective in meeting the training needs of young graduates and directing them into high-grade employment in industry, academia and the wider public sector.

A copy of the proceedings from the Teagasc Walsh Fellowship seminar can be viewed on: [www.teagasc.ie/publications/view\\_publication.aspx?publicationID=1609](http://www.teagasc.ie/publications/view_publication.aspx?publicationID=1609)

For more on Science Week visit: <http://www.scienceweek.ie>

# Pulsed electric fields in food production

A new post-doctoral researcher at Teagasc Food Research Centre, Ashtown, brings her expertise in the use of pulsed electric fields to improve food quality and safety in prepared foods.

Pulsed Electric Fields (PEF) involves the application of high-voltage energy (0.5-80kV/cm) in the form of short pulses (s to  $\mu$ s), leading to a minimum heating of the product.

The principles of PEF processing on food work through electroporation. This physical phenomenon is based in the response of the cell to PEF treatments, which could produce reversible or irreversible permeabilisation of the cell membrane, leading to a wide range of food applications. The reversible permeabilisation induces an increase in the mass and heat transfer rates between cells and their surroundings, enhancing the efficiency of processes such as fermentation, expression, extraction and diffusion of plant metabolites. On the other hand, the structural damages promoted by PEF have been demonstrated to be efficient for treating a large number of food products such as juices, milk, yogurts, soups, liquid eggs and even raw chicken.

The PEF generation schematic consists of high-voltage power supply to charge the capacitors and a discharge switch that releases the stored electric energy in the form of an electric field through the product. The PEF treatment chamber houses the electrodes delivering high voltage discharges to the food material placed between them. The product could flow through one or more treatment chambers configured for either static or continuous operations (Figure 1). Moreover, the efficiency of the treatment will also depend on the PEF processing parameters such as electric field strength, total treatment time, pulse shape, pulse frequency, pulse width, polarity mode and temperature.

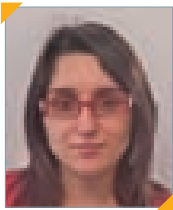

**Dr Ingrid Aguiló-Aguayo**,  
Post-Doctoral Researcher,  
Teagasc Food Research  
Centre, Ashtown  
Correspondence:  
Ingrid.Aguilo@teagasc.ie

## Potential applications of PEF for food

PEF can be used as a pretreatment of the drying process, in order to either enhance the drying

rates, or to obtain a higher quality product in terms of structure or solid content – for example, PEF-enhanced drying of red paprika in a fluidised bed dryer at 60°C for 6h and air velocity of 1m/s. The permeabilisation induced by PEF determined the enhancement of mass transport during drying. In fact, a reduction of approximately 25% of drying time was observed in PEF pre-treated samples in comparison to those control samples.

The permeabilisation induced by PEF on food membranes could also positively affect mass transfer in juice extraction. The use of PEF in combination with pressing steps at three-bar pressure was a suitable method of increasing apple juice yield, affecting the quality of extracted juice positively (Donsí *et al.*, 2010).

PEF could also enhance the extraction of metabolites of commercial interest, as well as enhance the recovery of soluble substances from different fruit and vegetable tissues. Some reports also indicate that PEF processing could represent a viable option for enhancing the extraction of phenolic compounds from skin cells of grapes during the maceration steps in winemaking process, without altering the quality and with moderate energy consumption. Since Ireland has an important brewing and cider production, the great potential of PEF for food recovery and waste reduction could offer Irish food industries important economical savings and high value products.

## Preservation of food products by PEF

PEF has been suggested as an alternative technology to obtain safe, high quality, nutritious foods with a shelf-life similar to that attained with conventional thermal pasteurisation. The optimisation of PEF treatment conditions, contributing to the standardisation of PEF processing for the destruction of both pathogenic and spoilage microorganisms in milk and several fruit juices has been developed. For instance, populations of *Salmonella enteritidis*, *Escherichia coli* and *Listeria monocytogenes* in melon juice were reduced by up to 3.7 log cycles when applying 35 kV/cm for 1,709s (Aguiló-Aguayo *et al.*, 2011). Although the processing conditions have a strong influence on the inactivation of microorganisms by PEF, the fluid medium, the target microorganism and the microbial characteristics also can exert an important



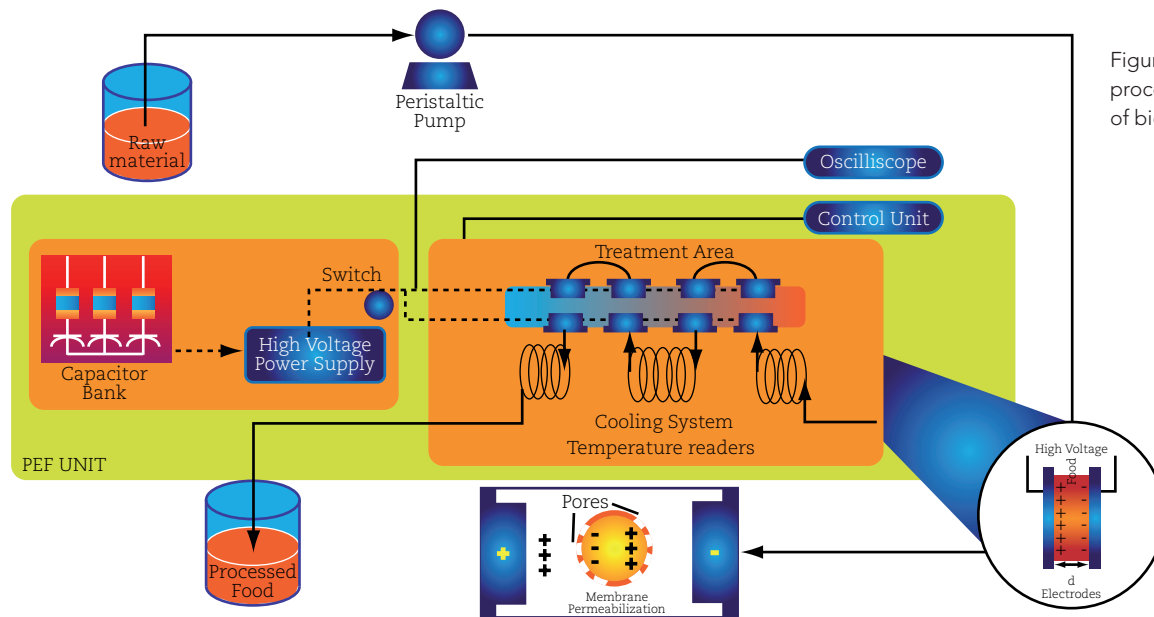

Figure 1. Diagram of the pulsed electric processing unit indicating the response of biological cells to treatments.

influence on the effectiveness of the treatment. Among bioactive compounds, vitamin C has been one of the most studied due to its heat-liability. In general, reports indicate that vitamin C is less affected by PEF treatments than by conventional treatments in very different products such as orange juice, apple juice, strawberry juice, tomato juice and fruit juice-soy milk blend. Recent studies have also suggested that the antioxidant potential of various fruit juices increased after PEF processing compared to the untreated juice because of the increment in their carotenoid content. An increase in the lycopene content and a significant enhancement in the total content of carotenoids in orange juice and in an orange juice-milk beverage have been reported after PEF processing. Although the reason for these results is not known, it could be speculated that carotenoid conversions could be triggered by the PEF treatments (Odriozola-Serrano et al., 2011).

Different susceptibilities to PEF processing have been observed for enzymes affecting the stability of health-related compounds, as well as important flavour compounds of juices such as lipoxygenase (LOX) and  $\beta$ -glucosidase ( $\beta$ -GLUC). An 80% reduction of LOX activity was observed when tomato juice was exposed to PEF, whereas only 33% and 20% inactivation was obtained when processing strawberry and watermelon juices, respectively. Nevertheless, similar LOX inactivation values were observed after processing by conventional heat treatments. On the other hand,  $\beta$ -GLUC was activated up to 115% after treating strawberry juice. The increment in the  $\beta$ -GLUC activity of PEF-treated juices was related with a high 2,5-dimethyl-4-hydroxy-3(2h)-furanone (DMHF) release, one of the major volatile compounds determining strawberry-like aroma, provided that this enzyme catalyses the hydrolysis of DMHF from its glucosidic precursor (Odriozola-Serrano et al., 2011; Aguiló-Aguayo et al., 2008). On the other hand, correlations between colour and inactivation of oxidative enzymes such as peroxidase or polyphenoloxidase have been also established for PEF-treated strawberry, watermelon, carrot and orange juices. PEF treatment led to an almost complete reduction in their initial enzyme activity, as well as a great preservation of their colour. PEF has been shown to be an interesting technology for food processing since high-quality, safe and shelf-stable products can be obtained without significant depletion of their

nutritional and sensory properties. Dr Aguiló-Aguayo has begun a project in Teagasc Food Research Centre, Ashtown, together with Dr Juan Valverde with the objective of determining the effects of PEF in carrot and broccoli food products and their associated bioactive content, related specifically to glucosinolates and polyacetylenes. The Institute of Food and Health, University College Dublin, will be also integrated in the project.

### Acknowledgements

The author acknowledges the financial support to the Generalitat of Catalunya (regional government) for the postdoctoral grant Beatriu de Pinós.

Dr Ingrid Aguiló-Aguayo would also like to thank Dr Juan Valverde, Dr Dilip Rai and Dr Michael Gaffney from Teagasc Food Research Centre, Ashtown and Dr James Lyng and Dr Nigel Brunton from University College of Dublin, for their contributions to the ongoing project.

### References

- Aguiló-Aguayo, I., Sobrino-López, A., Soliva-Fortuny, R., Martín-Belloso, O.** (2008). 'Influence of high-intensity pulsed electric field processing on lipoxygenase and  $\beta$ -glucosidase activities in strawberry juice'. *Innovative Food Science and Emerging Technologies*, 9: 455-462.
- Aguiló-Aguayo, I., Soliva-Fortuny, R., Elez-Martínez, P., Martín-Belloso O.** (2011). Book Chapter. Pulsed electric fields to obtain safe and healthy shelf-stable liquid foods, NATO Science for Peace and Security Series A: Chemistry and Biology, pages 205-222. ISBN: 978-940071099-3. Edited by: M. Hefnawy.
- Donsí, F., Giovanna, F. and Gianpiero, P.** (2010). 'Applications of pulsed electric field treatments for the enhancement of mass transfer from vegetable tissue'. *Food Engineering Reviews*, 2: 109-130.
- Odriozola-Serrano, I., Aguiló-Aguayo, I., Soliva-Fortuny, R., Martín-Belloso, O.** (2011). 'Pulsed electric fields processing effects on quality and health-related constituents of plant-based foods'. *Trends in Food Science & Technology*. doi:10.1016/j.tifs.2011.10.003.

# Producing electricity and heat from biomass

Biomass was the first feedstock used by mankind to generate energy. For millennia, and up until relatively recently, biomass was the predominant feedstock used for heat generation until humans were won over by the convenience and availability of fossil fuels. However, the first oil crisis in the early 1970s refocused attention on the use of renewable forms of energy including biomass.

feedstock for electricity generation in power plants. Electricity generation, however, is a less efficient way to generate energy compared to heat generation, as typically less than 50% of the energy in the feedstock leaves the power plant as electrical energy. The balance is heat energy, which is released to the atmosphere. In contrast, combined heat and power plants produce both electrical energy and heat energy (as hot water) and are consequently considerably more efficient than plants that only produce electrical energy. An essential prerequisite for such plants, however, is that there is a local demand for the hot water produced by the plant. Combined heat and power (CHP) technology has been available for some time and fossil fuel powered CHP plants are available in a range of sizes ranging from hundreds of kilowatts (KW) to hundreds of megawatts (MW). CHP plants, which use biomass as a feedstock are also available.

## Heat and electricity from biomass

Although biomass has traditionally been used to generate heat energy, it can also be used as a



**Dr John Finnan,**  
Research Officer,

**Padraig Brett,**  
Experimental Officer  
(now retired),

**Tom Ralph,**  
Research Technician,  
Teagasc, Crops,  
Environment and  
Land Use Research Centre,  
Oak Park, Carlow

Correspondence:  
john.finnan@teagasc.ie.

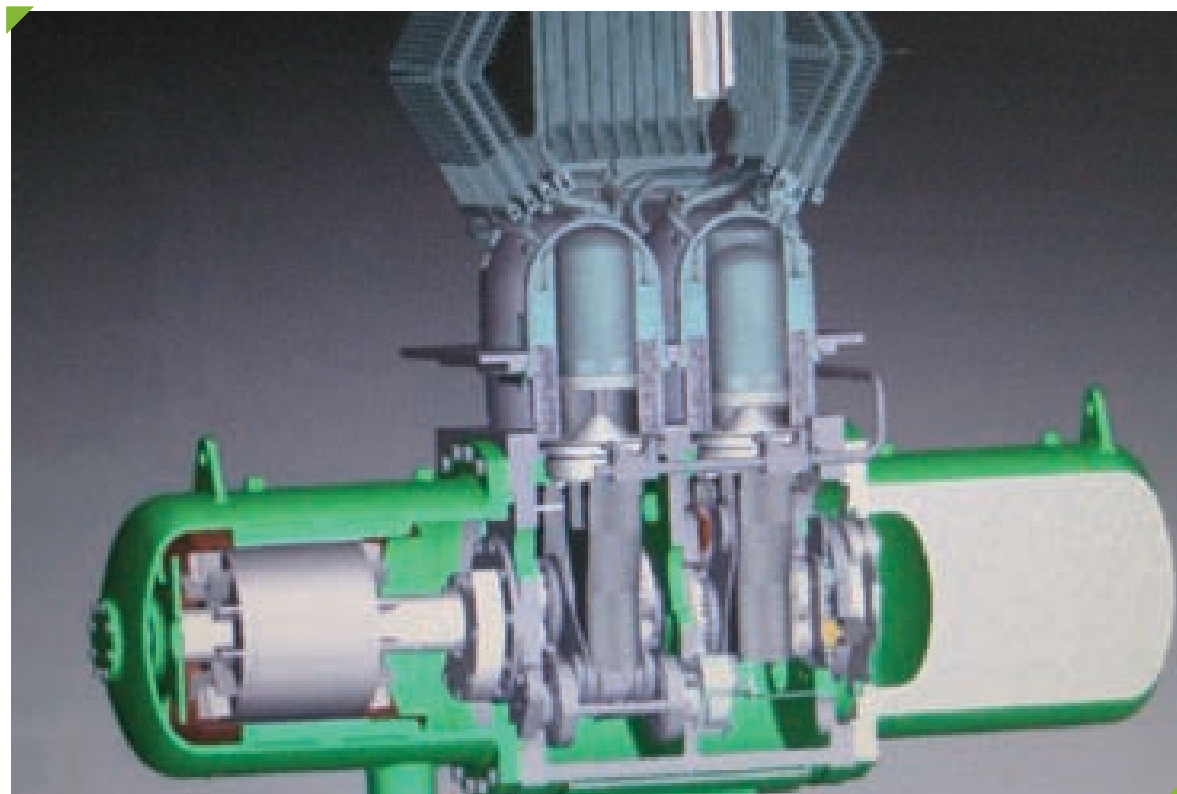

Figure 1: Stirling engine with heat exchangers (top), cylinders and pistons (middle centre), crankshaft (bottom centre) and generator (bottom left).

In such systems, biomass is often burnt in a furnace with the hot combustion gases used to generate steam to power a turbine from which electricity is generated. Biomass CHP plants are widely used throughout continental Europe to generate heat and electricity for local communities. The electricity generated by such plants (often called bioelectricity) is typically fed into the local grid; while the hot water is distributed to the local community via a district heating system. During summer, hospitals, public swimming pools and hotels ensure a constant demand for hot water.

### Small scale biomass CHP

Until recently, only quite large biomass CHP plants (>1MW) have been commercially available. More recently, however, smaller biomass CHP plants have started to come on the market. Small scale CHP systems currently available can be based on the combustion of biomass using the hot combustion gases to both heat water (thermal energy) and drive a turbine to generate electrical energy. Small scale turbines for such applications, however, are still in their infancy. Alternatively, biomass can be gasified to generate an energy-rich gas, which is subsequently combusted to generate thermal and electrical energy. Combustion of the gas can take place in an internal combustion engine, in which case the gas combustion drives a generator mounted to the crankshaft and electricity is generated when the engine turns while the exhaust gases from the engine are used to heat water. However, the use of internal combustion engines requires the gas to be cleaned in several expensive steps, before the gas enters the engine, in order to avoid corrosion problems. An alternative is to use an external combustion engine to generate electricity. External combustion separates the combustion of the fuel from power generation. As the fuel is not burnt in the engine itself, there is no need for the gas to be cleaned before combustion takes place. One example of an external combustion engine suited for this application is a Stirling Engine. A biomass CHP plant based on this principal has recently been installed at the Crops, Environment and Land Use Programme research centre at Oak Park, where it is being used to supply electricity and hot water. In this plant, the energy in wood chips is converted into an energy-rich gas in a gasifier before the gas is burnt in a combustion chamber. The heat generated from combustion is used to heat hot water but is also used to power a Stirling Engine and energy is generated when the engine rotates.

### Gasification

Gasification is a form of incomplete combustion in which a fuel is burnt in an atmosphere that is deficient in oxygen. During gasification, an energy rich gas, consisting principally of methane, carbon monoxide and hydrogen is formed but only a limited amount of heat is released. In contrast, carbon dioxide, water vapour and heat are released during combustion when a fuel is burnt in an atmosphere that is not deficient in oxygen. A helpful way to think about gasification is to consider that the energy in the fuel (biomass) is converted into an energy rich gas.

### Stirling Engine

The Stirling Engine was invented by Robert Stirling in 1816 and, for a time, was a rival to the steam engine. Both the steam engine and the Stirling Engine are examples of external combustion engines. In a steam engine a fuel, typically coal, is burnt and the energy from combustion is used to heat water to generate steam; in a subsequent step, the steam is used to drive a piston. A Stirling Engine is an example of a closed cycle engine in which the expansion and



Figure 2: Biomass CHP plant at Oak Park featuring the gasifier (black cylinder on right), gas combustion chamber (blue cylinder in the centre) and the Stirling engine (green unit attached to the combustion chamber).

contraction of a working fluid is used to turn a crankshaft. In many respects, a Stirling Engine is identical to an internal combustion engine as it features pistons that drive up and down cylinders to turn a crankshaft via connecting rods. However, the principal difference from an internal combustion engine is that the fuel does not enter the engine (closed cycle) but the fuel is burnt elsewhere and the energy from combustion is conveyed to the engine's working fluid through heat exchangers. The engine is driven by the expansion and contraction of its working fluid. In the CHP plant in Oak Park, the Stirling Engine is bolted onto the combustion chamber where gas produced in the gasifier is burnt and heat from the combustion of the gas is absorbed by the Stirling Engine through its heat exchangers. The engine starts to rotate once its working fluid (helium) absorbs sufficient heat; a generator on the crankshaft of the engine starts to produce electricity once the engine rotates.

### Oak Park biomass CHP plant

The biomass CHP plant at Oak Park has an output of 35 KWe (Kilowatts electrical) and 140 KWth (Kilowatts thermal). The plant uses wood chips at 40% moisture as a fuel; the chips are augered into the gasifier where gasification occurs in an atmosphere containing 16% oxygen. The gas from the gasifier is then conducted into a combustion chamber where it is burned. The heat from combustion is used to heat water in a water jacket around the combustion chamber but also to turn the Stirling Engine attached to the combustion chamber. Electricity from the Stirling Engine is fed into the sub-station at Oak Park and subsequently used around the Oak Park campus; while the hot water from the plant is used to heat a number of buildings on the campus. During 2013, hot water from the plant will also be used to heat the glasshouses at Oak Park. During the winter of 2011/2012 the plant generated 22 MWh (megawatt hours) of electrical energy and 138 MWh of thermal energy.

### Conclusions

Small biomass CHP plants are starting to become commercially available and, for locations with a constant heat demand, offer a means of defraying rising fuel and electricity costs while substantially reducing carbon footprint.

ACP Technician John Kennedy briefing farmers on the monitoring equipment in the Dunleer catchment in Co Louth.

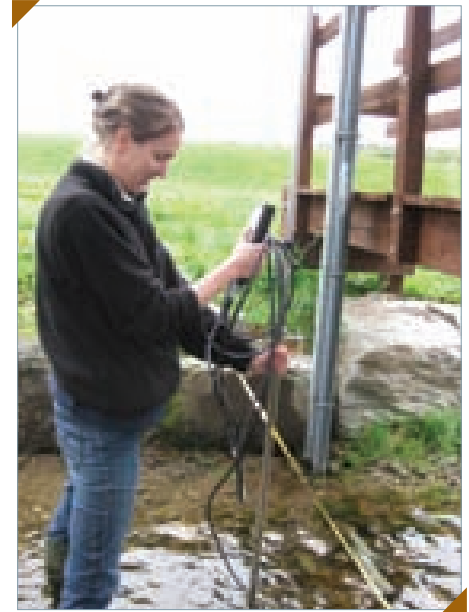

Dr Alice Melland measuring stream water flow in the Timoleague catchment in Co Cork.

# A grand challenge – good food, clean water



**Ger Shortle,**  
 Manager, Agricultural Catchments Programme, Teagasc Crops, Environment and Land Use Research Programme, Johnstown Castle, Wexford.

**Professor Phil Jordan,**  
 School of Environmental Sciences, University of Ulster at Coleraine, Northern Ireland.  
 Correspondence: ger.shortle@teagasc.ie

The Nitrates Directive (ND) and Water Framework Directive (WFD) set ambitious water quality targets for Ireland. In 2013, the National Action Programme for the Nitrates Directive is due for review, and Ireland's current derogation to farm above 170kg organic nitrogen per hectare will expire, unless Ireland can demonstrate to the European Commission that the current measures adequately protect water quality. Over the last four years, Teagasc has been working towards a successful outcome for Ireland. Ger Shortle (Agricultural Catchments Manager at Teagasc) and Professor Phil Jordan (University of Ulster) explain.

The Department of Agriculture, Food and the Marine's Food Harvest 2020 strategy focuses on acting SMART, thinking GREEN and achieving GROWTH. Teagasc has been given a key role in developing and transferring new knowledge and technologies and in strengthening the industry's skill base. Improving

the efficiency of production at farm level through improved nutrient management is central to achieving the targets; delivering a potential 'double dividend' of reduced costs of production and reduced risk of nutrient emissions from farming.

## Agricultural Catchments Programme

A key component of this effort is the Agricultural Catchments Programme (ACP), which is funded by the Department of Agriculture, Food and the Marine (DAFM) and works with farmers in evaluating the Good Agricultural Practice for Protection of Water Regulations (Nitrates Regulations). The aim of the regulations is to reduce agricultural nitrogen (N) and phosphorus (P) losses to help achieve the 'good status' targets for our water bodies as set out in the WFD.

The ACP works in six catchments, which were chosen as examples of grassland and arable agriculture on varying soil types and with different risks of loss of P and N to water. The programme is designed to assess the full chain of nutrient sources, mobilisation, pathways, delivery, and impacts in water. Socio-economic impacts (attitudinal, financial, farm practice) of the regulations are measured and analysed as well.

Phase 1 of the ACP finished at the end of 2011 and

Phase 2 is ongoing. The initial findings from Phase 1 have been published in scientific papers and, combined with the work of other Teagasc colleagues, these shed new light on how to meet the water quality challenges facing Irish farmers. The main conclusions from this work are summarised below.

### Managing phosphorus safely and efficiently

A major water protection policy in the Irish regulations is the management of nutrients to reduce excessive soil P levels (Index 4) to the optimum for farming (Index 3), thus reducing the risk of P loss to water. In five ACP catchments, between 6% and 26% of soils had P at Index 4, showing the legacy of historic P surpluses and large soil P variability was found at farm and field scale, indicating scope to correct imbalances with better nutrient management. We used a modelling approach to predict the time it would take for Index 4 soils to decline to Index 3. The outcomes suggested that, in extreme circumstances, it may take more than 20 years for the majority of Index 4 soils to come down to the optimum level, depending on the P offtakes in farm produce, the original soil P status, hydrological pathways and attenuation processes. For most grazed pastures, the model predicted that five to 20 years would be required for all Index 4 soils to reach Index 3. Crucially, these scenarios depend on a P deficit being incurred on Index 4 soils. These findings highlight the likely time lag between implementation of regulations by farmers and the decline of soil P to optimum levels and support a cautious approach to the introduction of additional measures before the impact of current measures is known. At national level, the prevalence of Index 4 soils has declined from 30% to 18% between 2007 and 2012.



Monitoring station in Ballycanew catchment, Co Wexford.

### Nutrient pathways from soil to water

In free-draining landscapes, source measures targeted at soil nutrient status and nutrient inputs may provide better mitigation of nutrient loss than mobilisation and delivery measures such as buffer strips, which target overland flow pathways. However, due to lag-times in below-ground nutrient movement, there are likely to

be significant delays between implementation of a source measure, such as limits on P and N application, and impact on water quality.

Low to moderate P losses (0.18kg/ha/yr to 0.79kg/ha/yr) were found in two grassland and two arable catchments. Higher P losses were primarily related to more poorly drained soils, rather than to land use or high soil P status. Furthermore, higher P concentrations in streams during drier summer periods were attributed to the reduced dilution of rural point sources. As a result, meeting water quality targets will be more challenging in the more poorly-drained catchments due to lower summer dilution of point sources and higher diffuse nutrient losses during storms. Disproportionately high P and N losses also occurred during the closed period for slurry spreading, confirming the risks of nutrient loss to water at that time of year.

At the other side of the scale, in an excessively-drained karst catchment in Co Mayo, it was found that high soil P status and a highly vulnerable aquifer did not lead to high P in the groundwater. This indicates that definitions of risk and vulnerability for P delivery in karst systems need further evaluation and this has led to the development of P loss susceptibility maps in these landscapes.

### Socio-economic indicators

We evaluated farmer attitudes and economic impacts, using data gathered by the National Farm Survey (NFS) and from within and outside the catchments.

Analysis of NFS data showed that, compared with the most efficient farms, there is scope on most farms to reduce fertiliser inputs while maintaining production. Potential cost savings on chemical fertilisers across all systems, on average, ranged from €38.9/ha to €48.5/ha. On manure management, we found that between 9% and 15% of farmers nationally would be willing to pay to import poultry and pig manures, respectively, and about twice that number would import if offered it for free. Manure application practices are also changing with more being applied in spring and adoption of new spreading technologies.

Our attitudinal survey found that just over half of farmers surveyed are sceptical of the validity of certain measures in the regulations, especially in the area of 'calendar farming'. However, some farmers indicated acceptance of environmental benefits from the regulations. Approximately half of catchment farmers indicated that they would not opt for provision of a fenced 10 metre riparian buffer zone under a five-year scheme. Farmers who were willing to install a 10 metre buffer zone would require an average payment, estimated at €1.51 per linear metre.

### Looking ahead

Teagasc is currently preparing a submission to the review of the Nitrates Action Programme (NAP) in 2013, based on the outcomes of Phase 1 of the ACP and other Teagasc research. With further support from DAFM, Phase 2 of the ACP is now under way and is building stronger collaborations within Teagasc and with other institutions. These outputs will support and inform the development of sustainable Irish farming and help keep the sector competitive into the future despite the challenges it is facing.

The Agricultural Catchments Programme is funded by the Department of Agriculture, Food and the Marine.

Detailed references for papers used in the preparation of this article can be found at [www.teagasc.ie/agcatchments/publications/](http://www.teagasc.ie/agcatchments/publications/)

# Cattle slurry variability: tools for improving precision of nutrient advice

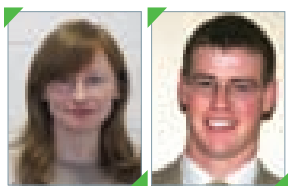

The nutrient concentration of cattle slurry is known to be highly variable. This affects the precision and reliability of nutrient management planning on farms in terms of nutrient supply requirements for crops when chemical fertilizers are replaced with slurry applications. Slurry nutrient advice is usually based on standard average values of total nutrient concentrations. The standard total nutrient concentration values, assumed by the Good Agricultural Practice (Nitrates) Regulations, are higher than slurry often contains in reality.

Knowledge of the slurry nutrient concentration through laboratory analysis helps to improve the precision of slurry nutrient applications. However, obtaining a representative slurry sample is difficult without complete agitation of the tank, due to stratification of slurry in storage. Slurry agitation is usually carried out immediately prior to land spreading and this means that laboratory results would not be available in time for spreading. A reliable method of sampling slurry prior to agitation would facilitate more timely availability of laboratory results.

### Objective of this study

The objective of this study was to investigate methods for improving the estimation of total nutrient concentration in slurry. Three issues were investigated as follows:

- sampling methods for laboratory analysis allowing farmers to overcome the time delay between sampling and the availability of laboratory results;

- on-farm quick assessment tools for analysing slurry; enabling the estimation of slurry nutrient concentration quickly and on-site; and,
- factors affecting nutrient concentration in slurry to improve the accuracy of assumed average nutrient concentrations.

### Comparing slurry sampling methods

The nutrient concentration in slurry sampled post agitation (using a bucket inserted into the tank and retrieved using an attached rope) was compared with a 'tube-sampler' method used a number of days prior to agitation. Seven slurry tanks were sampled in and around Teagasc, Johnstown Castle, Co Wexford. The tube sampler consisted of a 6cm diameter plastic pipe that was inserted to the full depth of the unagitated slurry tank. A ball stopper attached to a rope was then applied to the base of the pipe as a seal by pulling the rope up through the centre of the pipe. Three full columns of slurry were extracted from the tank and sub-sampled for analysis. There was a wide range in nutrient and slurry dry matter concentrations between tanks. For example, the dry matter concentration ranged from 1.7% to 10.3%. The sampling method did not have a significant effect on the dry matter or nutrient concentration within each tank. This shows that the tube sampler can be used to take a representative slurry sample in advance of agitation, leaving enough time for laboratory analysis results to be available on the day of slurry application.

### On-farm quick assessment tools

Having a tool for making a quick, on-the-spot assessment of slurry nutrient concentration would help farmers to adjust slurry application rates on the move, and to achieve better utilisation of the available nutrients. In this study, three commercially available tools were demonstrated to groups of farmers. These farmers were subsequently surveyed for their

**Patricia Berry**,  
Teagasc Walsh Fellow,  
**Stan Lalor** and **Dr David Wall**,  
Research Officers, Teagasc,  
Crops Environment and Land  
Use Programme,  
Johnstown Castle,  
Co Wexford.  
**Dr John Quinn**,  
School of Biological Sciences,  
Queen's University, Belfast,  
Co Antrim.  
**Dr Peter Frost**,  
Agri-Food and Biosciences  
Institute, Hillsborough,  
Co Down.  
Correspondence:  
stan.lalor@teagasc.ie



Figure 1: Slurry hydrometer with graduated scale used to estimate the slurry dry matter concentration in a well-mixed slurry sample.

opinions on the usability and/or value to them of each tool. The tools selected were: a slurry hydrometer that estimates the slurry dry matter concentration (Figure 1), and two tools that estimate the ammonium-N concentration of slurry. The slurry hydrometer showed the highest potential for adoption on farms, as the slurry dry matter could be used to estimate the concentrations of all nutrients (N, P, K), whereas the other two tools only gave an estimate for ammonium-N.

### Factors affecting nutrient concentration

A total of 75 slurry samples were collected from dairy and beef farms, along with supporting data on animal type, animal housing and animal diet. The mean and range of dry matter, N, P and K concentrations in the 75 samples are shown in Figure 2. The mean concentration of N, P and K were lower than those assumed by the GAP regulations and in previous advice. Analysis of this dataset found no definitive relationships between slurry nutrient concentration and the farming system variables that were recorded. However, the slurry nutrient concentration was correlated with slurry dry matter concentration (Figure 2), indicating that the slurry dry matter can be used to estimate the nutrient concentration.

### Conclusions

The following conclusions can be made based on the results of this study:

- A tube sampler can be used to take a representative slurry sample prior to agitation so that laboratory analysis results can be received in time to make slurry application rate adjustments based on actual nutrient values.
- The adoption of quick tools on farms is more likely if the tool can estimate a range of nutrients. Farmers perceived the slurry hydrometer to be the most useful quick tool and the one they would be most likely to purchase.
- Cattle slurries on Irish farms have a wide range of nutrient concentrations, and the average nutrient concentrations found in slurry were lower than those assumed in previous advice and in the GAP regulations. The farm system, management system and diet did not predict slurry nutrient concentration based on the data collected. However, slurry dry matter concentration was a good predictor; therefore, the slurry hydrometer shows potential to improve the estimation of slurry nutrient concentration on farms.

### Acknowledgements

Funding received from the Teagasc Walsh Fellowship Scheme is gratefully acknowledged. The authors also wish to thank the farmers and advisors who contributed to the study through survey participation and sample collection.

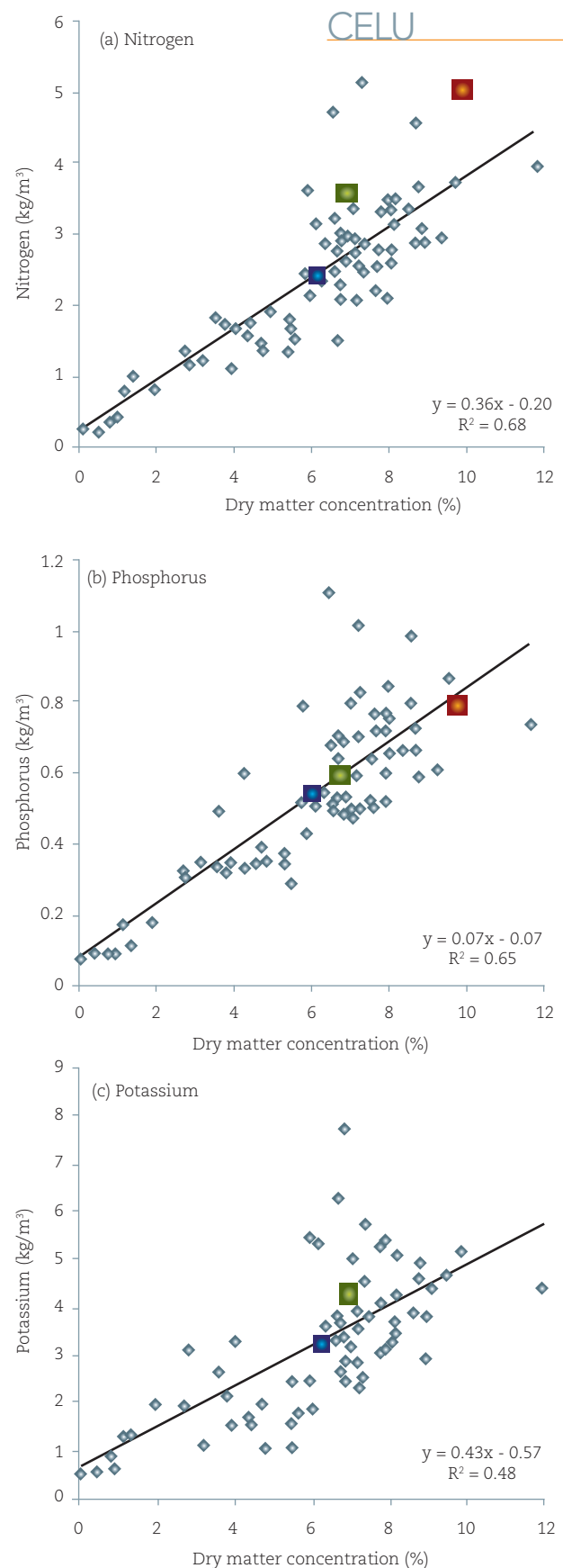

Figure 2: Relationship between slurry dry matter and nitrogen (a), phosphorus (b) and potassium (c) in the 75 slurry samples collected on farms. Values assumed in previous nutrient advice (green square) and current GAP regulations (red square) are also shown. (Note that no value is assumed for potassium in the GAP regulations). The mean value for the sample in the study are shown by the blue square.



# Productivity and income

Productivity growth will be the key driver of income in Irish agriculture. Researchers in the Rural Economy and Development Programme outline lessons learned from the terms of trade of Irish agriculture.

It is becoming increasingly clear that the future of Irish agriculture rests on productivity growth and adherence to environmental standards.

Rising agricultural commodity prices in recent years have driven the recent increases in the output value of the Irish agriculture sector. The increase in the level of agricultural prices and the value of agricultural sector output are viewed by many as indicators of an improvement in the fundamental economic performance of the sector. To what extent is this interpretation accurate and what, in the medium to longer term, will be the key drivers of the economic prospects of the Irish agricultural sector?

Increases in the value of output of the agriculture sector are welcome and arise in tandem with increased value added in downstream processing industries. However, an increase in output value need

not necessarily translate into an increase in incomes. In fact, if the rate of output price growth is outstripped by the rate of growth in input prices, agricultural sector incomes can stagnate or decline. It is important to appreciate that the income arising in agriculture comprises the value of subsidies received plus the difference between output value and the total cost of production. If the volume of output and the volume of input use (and subsidy receipts) are held constant, faster growth in input prices than in output prices will reduce incomes and the welfare of farmers and others involved in agriculture.

Figure 1 graphs the historical evolution of agricultural output and agricultural input indices between 1961 and 2011. What is clear is that, for most of the last 50 years, the evolution of output and input prices was very close, though accession to the EEC in the early 1970s led to growth in output prices that initially exceeded input prices.

### Terms of trade

Economists term the ratio of agricultural output and input price indices the “terms of trade” or TOT of agriculture. Figure 2 plots the TOT of Irish agriculture since 1961. Over the period 1961 to 1992, the TOT of Irish agriculture declined by 5%. This decline occurred despite the large increases in Irish agricultural output prices associated with accession to the EEC in the 1970s. The deterioration in the TOT of agriculture accelerated following the switch from market price support to direct income support that began with the MacSharry reforms of 1992. Between 1992 and 2011 Irish agriculture’s TOT declined by over 22%. This acceleration in the rate of decline in agriculture’s terms of trade has been driven by strong growth in the prices of agricultural inputs such as energy, feed and fertilizer.

The decline in the TOT of agriculture is not unique to Ireland. This describes the experience of agriculture in most developed economies. Do declining TOT imply that



**Dr Kevin Hanrahan and Trevor Donnellan** are Principal Research Officers in the Agricultural Economics and Farm Surveys Department, Teagasc.  
Correspondence: kevin.hanrahan@teagasc.ie

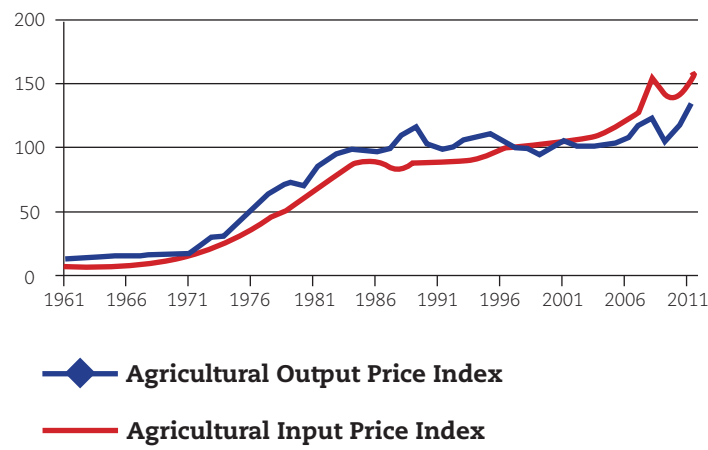

Figure 1: Irish agricultural output and input price indices 1961-2011 (2000=100). Source: Central Statistics Office.



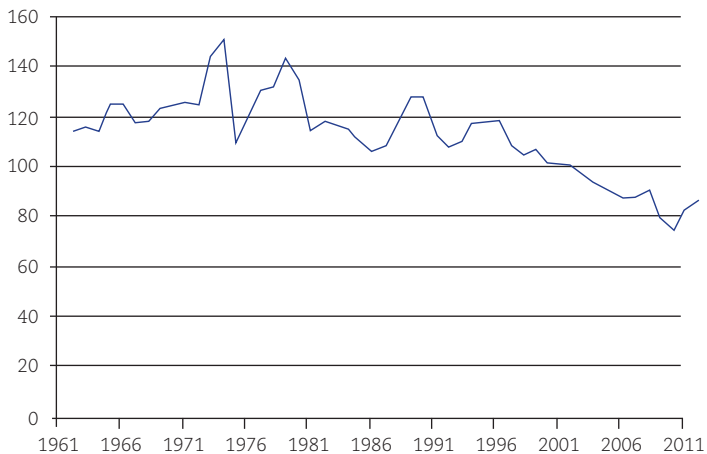

Figure 2: Irish agriculture's terms of trade: 1961-2011 (2000=100).  
Source: Derived from Central Statistics Office data.

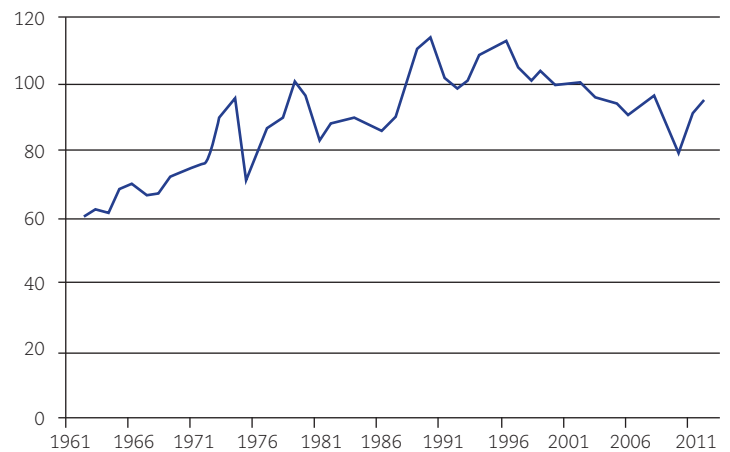

Figure 3: Irish agriculture's single factoral terms of trade 1961-2011 (2000=100).  
Source: Author's estimate.

agricultural incomes have also declined? If future growth in output prices is less than growth in input prices does that imply a contraction in future agricultural incomes?

### Productivity

While TOT ratios are very useful for describing the cost-price squeeze faced by agriculture, it ignores improvements in agricultural productivity. Productivity measures the increase in output over time from a fixed volume of inputs. Improvements in productivity have to be accounted for when assessing what TOT ratios imply about the welfare of those working in agriculture. The anticipated productivity growth of Irish agriculture also needs to be accounted for when assessing whether stagnant or declining TOT in the future necessarily translate into stagnant or declining agricultural incomes.

Using published estimates of Irish agricultural productivity growth for the period 1960-2000 (Matthews, 2000; Newman and Matthews, 2007) and a conservative assumption that the productivity performance since 2000 is equal to the performance for the period 1990-2000, we calculate the single factoral terms of trade (SF-TOT) for the period 1961-2011. The SF-TOT measure (Fleming, 2007) adjusts the TOT ratio so as to account for the growth in the total factor productivity of agriculture. As illustrated in Figure 3, the path of the SF-TOT ratio differs substantially from the TOT ratio. Over the period 1961-2011 the SF-TOT ratio increased at an annualised rate of just less than 1%. The decline in SF-TOT since 1992 reflects a slow down in productivity growth, higher growth in input prices and the reduced market price support that resulted from the MacSharry and subsequent CAP reforms. The receipt by agriculture of significant direct income support payments means that the decline in SF-TOT since the early 1990s should not be conflated with a decline in the welfare of those working in agriculture.

### Income

While the Common Agricultural Policy will continue to provide income support to Irish agriculture, it will not be the basis for future growth in the incomes of those working in the Irish agricultural sector. Instead, growth in the productivity of Irish agriculture will increasingly be the key determinant of the path of agricultural

income in Ireland. In this respect, Irish agriculture will increasingly resemble other sectors of the Irish economy, with incomes increasingly determined by economic performance.

The slowdown in productivity growth in Irish agriculture in the 1990s and 2000s was, in part, due to the restrictions placed on the growth of the Irish dairy sector by the EU dairy quota system. In drystock, the complex system of coupled direct payments is likely to have also reduced the incentive to improve productivity. The ending of the EU dairy quota system raises the prospect of growth in the volume of Irish agricultural output. To what extent will the evolution of output and input prices and productivity support such growth?

In the medium to longer term, growth in the volume of Irish agricultural output is unlikely to be supported by growth in the TOT of agriculture. Growth in energy and fertilizer prices is likely to continue to outstrip growth in agricultural output prices. Growth in the volume of output, in the absence of improved productivity, will require a corresponding increase in the volume of input usage resulting in little or no improvement in incomes.

Improvements in the productivity performance of Irish agriculture will be crucial to the achievement of growth such as that set out in the Food Harvest 2020 targets. In the future, Irish agriculture may operate in a world in which environmental policy supplants traditional agricultural policy as the key policy determinant of sectoral performance. In such a setting, improving the productivity performance of Irish farms will be one of the key avenues to improving farm incomes and augmenting the environmental sustainability of Irish agricultural production.

### References

- Matthews, A.** (2000) 'Productivity Growth in Irish Agriculture'. *Journal of the Statistical and Social Inquiry Society of Ireland*, XXIX: 317-367.
- Newman, C. and Matthews, A.** (2007) 'Evaluating the Productivity Performance of Agricultural Enterprises in Ireland using a Multiple Output Distance Function Approach'. *Journal of Agricultural Economics*, 58: 128-151.
- Fleming, E.** (2007) 'Use of the Single Factoral Terms of Trade to Analyse Agricultural Production'. *Australian Journal of Agricultural and Resource Economics*, 51: 113-119.

# Could 'lab grown' meat really be on the menu?

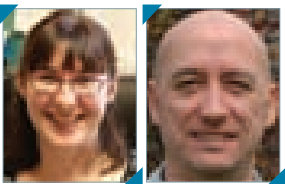
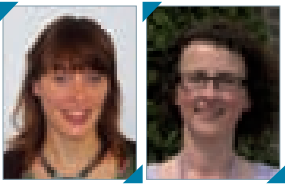

In the context of the debate on battling to feed an increasing global population in a sustainable way, the consequences of current agricultural practices and conventional livestock production are being examined and alternatives sought. The authors here examine Irish consumers' reactions towards the concept of a novel meat production system, 'in vitro' meat, which is currently being put forward by some international scientists as a way of satisfying the population's growing hunger for meat.

By 2050 the world's population is projected to reach 9.1 billion, with significant growth projected to take place in developing countries. Alongside this, urbanisation and income levels will continue to rise, which will result in an increased demand for food, particularly meat. Consequently, the FAO (2009) suggest that food production needs to increase by 70% and annual meat production needs to reach 470 million tonnes, up over 200 million tonnes on current levels (FAO, 2009). Based on such forecasts, global food production must become more sustainable, while concurrently facing obstacles including increased competition for natural resources, competition between food, feed and biofuel, and operating in a carbon-constrained economy. In light of such obstacles to increasing global food supply, some scientists are exploring and researching the possibility of growing meat *in vitro* in a laboratory. The technology involved is currently used mainly to grow cells for pharmaceutical applications. However, several international research groups have been experimenting over the past decade in the production of *in vitro* meat.

## What is *in vitro* meat?

An *in vitro* meat production system (IMPS) would involve culturing muscle tissue from a donor animal in a liquid medium on a large scale. The technical

challenges of growing tissue *in vitro* to resemble a meat-based product are many. Cells would be grown in a growth medium containing amino acids, glucose and a variety of growth factors (which may be provided by foetal bovine serum or plant extracts). Force would then be applied, causing the cells to fuse and form muscle fibres. According to scientists, the utilisation of *in vitro* meat in ground, processed meats such as hamburgers and sausages is, at present, more technically feasible than its presentation in a form resembling traditional meat cuts (Datar and Betti, 2010).

## The 'yuck factor'

Aside from potential environmental benefits, those in favour argue that an IMPS would result in reduced waste, as unwanted skeletal tissue and offal would not be produced. In addition, ethical concerns with regard to animal welfare, disease and intensive rearing practises could be addressed. Proponents also argue that meat produced *in vitro* could be cultured in sterile, controllable conditions, potentially minimising the risk of foodborne illness (Thornton, 2010); however, this is open to debate. Furthermore, they say that its nutritional composition could be altered. Aside from the implications for conventional farming, the rural landscape and wider society, the commercial implementation of such a system would undoubtedly pose challenges given its perceived unnaturalness and what some have termed the 'yuck factor' for consumers. On the supply side, scientists recognise that the process would be expensive and resource intensive, with the scaling-up of production undoubtedly creating challenges. The question therefore arises, could such a system ever become a commercial reality?

## From petri dish to dinner plate?

The development of an alternative meat production system in the tissue engineering of skeletal muscle remains hard to grasp and, indeed, somewhat unrealistic. However, the concept has courted some media coverage of late. Further evidence of its apparent nearness to reality is reflected in the fact that in 2008 the animal rights body PETA (People for

**Dr Emma Dillon,**  
Research Officer, Teagasc.

**Dr Maeve Henchion,**  
Head, Agri-Food Business and  
Spatial Analysis, Teagasc  
Food Research Centre, Ashtown.

**Gráinne Greehy,**  
Teagasc Walsh Fellow,  
Department of Food Business &  
Development, University College  
Cork and Teagasc Food Research  
Centre,  
Ashtown.

**Dr Mary McCarthy,**  
Senior Lecturer, Department of  
Food Business &  
Development, University College  
Cork.

**Dr Sinéad McCarthy,**  
Research Officer, Teagasc.

**Dr Gwilym Williams,**  
Lecturer, Biotechnology, School  
of Biological Sciences,  
Dublin Institute of Technology,  
Kevin Street.

Correspondence:  
Maeve.Henchion@teagasc.ie



the Ethical Treatment of Animals) announced a \$1 million prize for the first commercially viable *in vitro* chicken product to be produced by June of this year. This deadline has now passed without success and the contest has been extended until January 2013. However, a team of tissue engineers at Maastricht University claim to be very close to unveiling an *in vitro* hamburger. IMPS is currently in the developmental stage, and while its commercial feasibility is not yet clear, it is gaining increasing media attention (*Irish Independent*, *New York Times*). Therefore, it is useful to gain insights into consumer acceptance of this evolving and potentially controversial technology at this early stage. Irish consumer insights and reactions towards *in vitro* meat were therefore examined in research undertaken by Teagasc and UCC as part of a wider research project examining consumer acceptance of a range of novel food technologies.

### Will consumers swallow *in vitro* meat?

A qualitative research approach was taken, involving observations of a one-to-one deliberative discourse (conversation) between a meat scientist and consumers from different socio-economic backgrounds. Given the abstract nature of the technology, consumers were presented with pre-defined scenarios, illustrating the benefits and risks (from an individual, societal and environmental perspective) of a number of hypothetical *in vitro* meat applications across animal types. These were futuristic in nature and were set in the context of a rising world population and increasing demand for food. The aim was to elicit consumers' responses to information about *in vitro* meat products presented as a viable alternative to potentially scarce, conventionally produced meat products in the year 2050. The first hypothetical application illustrated how *in vitro* meat could be used as an alternative to conventionally produced minced meat (this could be cooked by consumers or used as an ingredient by food processors). The second outlined how more structured cuts of meat could in theory be produced; e.g., *in vitro* produced substitutes for traditional beef steak, chicken and fish fillets. Consumers also participated in pre- and post-discourse interviews (n = 5; 15 observations in total).

Participants initially reacted negatively towards the concept of *in vitro* meat, perceiving it to be unnatural. Their overall evaluations of such products were based on trade-offs between perceived benefits and costs. One interesting aspect in terms of acceptance was the issue of perceived personal relevance versus societal relevance. Particular product characteristics and personal demands from food (e.g., taste and texture) appeared more important to individuals than the wider societal issues of the environment, greenhouse gas reduction and global food supply. The suggestion that the taste and texture of *in vitro* meat products might be sub-optimal presented a potential 'tipping point' in consumer acceptance. This was particularly evident when *in vitro* steak was discussed.

Participants generally felt that any sensory shortcomings arising with a minced product could be more easily overcome by using sauces in cooking, etc. However, they were receptive towards the possibility of producing tailor-made *in vitro* meat products for specific medical or dietary needs. Overall, consumers tended to be supportive of the technology on animal welfare grounds. That said, this was influenced by the type of meat (i.e., participants were more favourable towards *in vitro* chicken than beef). Indeed, most were willing to pay extra for an *in vitro* alternative to intensively reared chicken or farmed fish. Thereby indicating that consumers displayed a 'hierarchy of approval'; such a hierarchy has also previously emerged regarding acceptance of different genetically modified food applications Hallman (2000).

Individual perspectives and values (e.g., attitudes towards nature and the environment) also framed participants' overall attitudes. In particular, most questioned the potential impact of this technology on farming practices within Ireland and the rural landscape.

### Farming for the future

Within the broader sustainability debate the environmental impact of agriculture and conventional livestock production is currently the focus of much attention. Despite consumers recognising the potential advantages of an IMPS, the main barriers to acceptance identified in this research related to texture, quality and the perceived unnaturalness of the process. In general, specific product and individual characteristics and broader societal issues (particularly those relating to sustainability) arose as important factors influencing consumer receptivity towards *in vitro* meat. Consumers recognised the need for more sustainable animal production approaches but whether the production of *in vitro* meat is a viable alternative remains to be seen.

### Acknowledgements

This research was funded by the Food Institutional Research Measure of the Department of Agriculture, Food and the Marine. The authors wish to acknowledge the contribution of Dr Ruth Hamill, Teagasc Food Research Centre, Ashtown, to this research.

### References and further reading

- Datar, I. and Betti, M. (2010). 'Possibilities for an *In Vitro* Meat Production System.' *Innovative Food Science & Emerging Technologies* 11: 13-22.
- Food and Agriculture Organisation (FAO) of the United Nations (2009). 'How to Feed the World in 2050'. *Report from the High-Level Expert Forum*, Rome, Italy, 12th-13th October 2009.
- Hallman, W.K. (2000). 'Consumer Concerns About Biotechnology: International Perspectives.' *Food Policy Institute Publication No.* RR-0602-003.
- Jason White (12/11/11). 'Meat even vegetarians can eat', *Irish Independent* available at [www.independent.ie/world-news/meat-even-vegetarians-can-eat-2933076.html](http://www.independent.ie/world-news/meat-even-vegetarians-can-eat-2933076.html)
- 'Who's afraid of fake meat?' *The New York Times* (13/07/10). available at <http://ideas.blogs.nytimes.com/2010/07/13/whos-afraid-of-fake-meat/>
- Thornton, P.K. (2010). 'Livestock Production: Recent Trends, Future Prospects.' *Philosophical Transactions of The Royal Society, Biological Sciences* 365: 2853-2867.

# Replacement heifer management to maximise performance

Teagasc researchers make recommendations on rearing dairy replacement heifers.

On many Irish dairy farms heifer rearing receives low priority. As a result, potential herd performance is not being realised. Well-bred maiden heifers have the potential to substantially improve herd profitability. They should represent some of the highest genetics in the herd. If calved early they have a capacity to significantly improve herd-calving pattern, and, if mated to high EBI sires, will provide a source of early-born high genetic merit replacement heifers for the future.

In order to capitalise on these benefits the following approach is recommended:

- Achieve target live weights to ensure heifers are cycling (reach puberty) before the start of the breeding season and optimise performance as cows
- Synchronise heats (resulting in compact calving) and minimise heat detection efforts
- Mate heifers with an easy-calving high EBI AI sire

If these guidelines are put into practice, it is envisaged that approximately 70% of heifers would calve in the first three weeks and 95% in the first six weeks of the calving season.

## Synchronisation

In many cases, dairy replacement heifers are transferred to out-farms, and are bred by natural service sires because of the inconvenience of heat detection and animal assembly for AI. Accurate detection of heat in a group of cycling heifers can be challenging. At Moorepark, tail paint and three-times daily observation for heats is used in conjunction with a synchronisation protocol. Prostaglandin-based (e.g., Estrumate®, Lutalyse® or Prosolvin®) oestrous synchronisation treatments offer a low-cost, low-labour input option for concentrating heats, and enabling farmers to capitalise on easy calving high genetic merit AI sires. Prostaglandin-based protocols are routinely used at Moorepark, and have been

generally found to be very successful. Two slightly different approaches can be taken (see Figure 1).

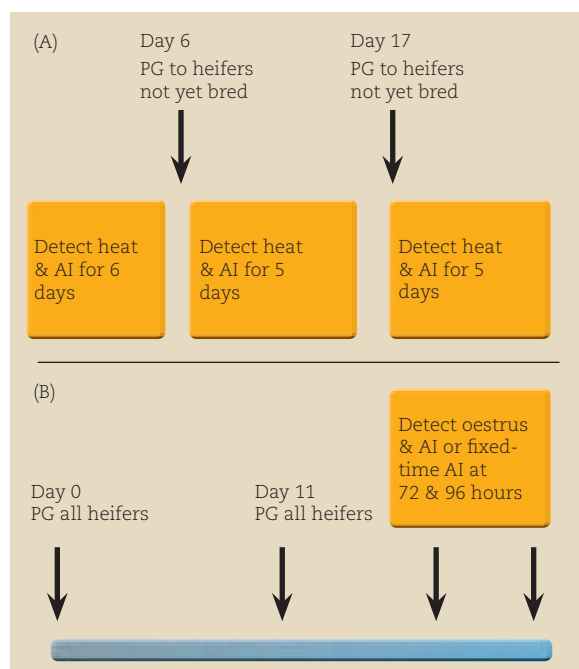

Figure 1: Two commonly used prostaglandin-based synchronisation protocols for heifers.

(A) Most commonly used heifer synchronising protocol.

(B) Alternative protocol requiring shorter duration or no heat detection.

If heifers are mature and cycling, submission rates of 90% and conception rates of 60%, or greater, should be achieved. Furthermore, most (approximately 70%) of the non-conceiving heifers would be expected to return to oestrus quite synchronously (within a few days of each other). This offers some convenience in terms of potential re-insemination. A second round of AI should result in over 80% of heifers calving to AI. One key determinant of success for prostaglandin-based programmes is that heifers must have reached maturity and be cycling prior to implementation. If heifers are not already cycling the treatment will not work.

## Targets to ensure cyclicity pre-breeding and optimum cow performance

As part of the initial stages of the large on-farm

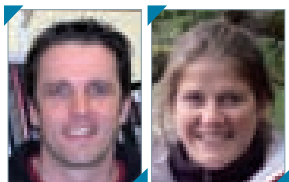
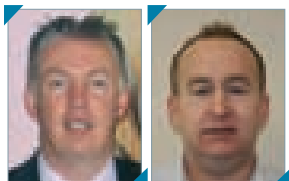

**Dr Frank Buckley**,  
Principal Research Officer,

**Dr Laurence Shalloo**,  
Senior Research Officer,

**Dr Stephen Butler**,  
Research Officer,

**Dr Emer Kennedy**,  
Research Technologist,  
Teagasc, Animal and Grassland  
Research & Innovation Centre,  
Moorepark, Fermoy, Co Cork.

Correspondence:  
frank.buckley@teagasc.ie



	HF	NZ	HF*NZ	NR	HF*NR	J	HF*J
Maiden heifer LW(kg)	330	315	330	315	330	240	295
Pre-calving LW (kg)	550	525	550	525	550	405	490

HF = Holstein-Friesian, NZ = New Zealand (Kiwi Friesians), NR = Norwegian Red, J = Jersey.

Table 3: Average live-weight (LW) targets for maiden heifers at breeding and for heifers pre-calving by breed/crossbreed.

	Live weight (kg) at mating start date				S.E.M.	Significance
	≤290	291-316	317-342	≥343		
Pubertal rate (%)	55 <sup>a</sup>	75 <sup>b</sup>	77 <sup>b</sup>	81 <sup>b</sup>	3.2	***
Calving date (lactation 1)	Mar 15 <sup>a</sup>	Mar 5 <sup>b</sup>	Mar 1 <sup>b</sup>	Feb 27 <sup>b</sup>	3.9	*
Longevity (%)	47	52	62	56	4.4	0.09

a, b Means within a row with different superscripts differ (P < 0.05).

Table 1: The effect of live weight at MSD on pubertal rate, subsequent calving dates and longevity (survival from MSD as heifers to lactation 3) over three lactations.

	Live weight (kg) at mating start date				S.E.M.	Significance
	≤290	291-316	317-342	≥343		
MS yield (kg) Lactation 1	383 <sup>a</sup>	394 <sup>b</sup>	404 <sup>c</sup>	417 <sup>d</sup>	4.3	*
Lactation 2	448 <sup>a</sup>	462 <sup>b</sup>	467 <sup>b</sup>	478 <sup>c</sup>	5.4	*
Lactation 3	474 <sup>a</sup>	487 <sup>ab</sup>	496 <sup>bc</sup>	503 <sup>c</sup>	7.4	*
Protein (%)	3.47	3.48	3.50	3.52	0.020	NS
Fat (%)	4.01	3.98	4.07	3.99	0.041	NS
LW (kg) Lactation 3	498 <sup>a</sup>	519 <sup>b</sup>	552 <sup>c</sup>	579 <sup>d</sup>	5.7	***

a-d Means within a row with different superscripts differ (P < 0.05)

Table 2: Effect of live weight (LW) at MSD as heifers on the 305 d milk solids (MS) yield, protein (%), fat (%), live weight (LW) over three lactations.

Norwegian Red crossbreeding study run by Moorepark, almost 900 Holstein-Friesian heifers were monitored. Immediately prior to mating start date (MSD) on the participating farms, the herds were visited to weigh, body condition score (BCS) and scan each heifer. Large variation existed between herds with regard to heifer weights, BCS and the proportion of heifers cycling. Analysis of the data clearly highlighted the importance of having heifers well grown and in good condition prior to breeding in order to achieve a high proportion of heifers cycling but also to optimise subsequent performance as cows.

While age is an important determinant of the timing of puberty, the findings of the current study indicate that its influence on pubertal rates at MSD and subsequent cow performance are small in typical Irish seasonally-calved herds (67% pubertal with the youngest heifers and 71% pubertal with the oldest heifers). Furthermore, the production potential of ‘younger’ versus ‘older’ heifers was identical during all three lactations investigated. However, both live weight (LW) and BCS at MSD do significantly affect both pubertal levels and subsequent production performance (see Tables 1 and 2). As evidenced by the data, as well as developing into larger cows, the heifers that were heavier at MSD had significantly greater production potential – not only during first lactation but as a long-term effect. Interestingly, the variation in milk solids production was driven by differences in volume rather than differences in composition. Survival differences were also evident.

### Economic analysis

Economic analysis showed that larger, well grown heifers are more profitable due to superior production potential, all else being equal. However, due to the finding of poorer reproductive efficiency with heifers grown to in excess of 343kg at MSD, heifers at approximately 330kg at MSD are deemed optimal. This will correspond to mature cow LW of approximately 550kg.

It is acknowledged that target LW will be influenced by breed/crossbreed. Pertinent recommendations are therefore presented in Table 3. The target weights at breeding are equivalent to 60% of target pre-calving LW at first calving.

### Choice of sire

The choice of sire used on maiden heifers is important from two key perspectives:

#### Calving difficulty must be minimised

Data from the large Moorepark ‘Farm Fertility Study’ carried out during 1999 and 2000 across over 80 commercial dairy herds highlighted the negative consequences of calving difficulty. Heifers were found to be twice as likely to experience calving difficulty compared to mature cows. The economic impact of calving difficulty is due to reduced reproductive efficiency and cow productivity, as well as increased morbidity, mortality and culling. The target should always be the delivery of a viable calf and a smooth transition for the heifer into the milking herd. Sires with direct calving difficulty predicted transmitting ability values of 1.5% or less (consult figures provided by ICBF) are recommended as suitable for use on maiden dairy heifers.

#### Genetic progress must be maximised

Profitability of the dairy system going forward can only be maximised if the genetic potential of the herd is capable of meeting the challenges posed by a grass-based system and the prevailing economic circumstances. The potential to expand is just around the corner. The availability of high genetic merit replacements will be restrictive. It is logical to put effort into ensuring all maiden heifers are mated to high EBIs. Those not conceiving to AI should be mated with a carefully selected (high EBIs) easy-calving dairy stock sire. The result should be 20% to 25% more replacements available three years hence.

### Key points

- Manage heifers to achieve target LW (330kg for HF) and BCS of 3.25 pre-breeding.
- Use a prostaglandin-based synchronisation protocol to concentrate heats.
- Mate heifers with easy-calving high EBIs dairy sires.

This research is Teagasc core-funded.



# Expansion post 2015 – room for increasing stocking rate

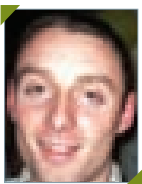

**Dr Brian McCarthy,**  
Research Officer,  
Teagasc, Animal and Grassland  
Research & Innovation Centre,  
Moorepark.  
Correspondence:  
brian.mccarthy@teagasc.ie

It is envisaged that post-EU milk quota abolition, overall land or, more specifically, the amount of land around the milking parlour (i.e., the grazing platform) will become the most limiting factor to increased milk production. Post-quotas, with profitability per hectare as the core objective, Irish grass-based production systems must focus on increasing home-grown pasture production and utilisation through new feed management objectives, increased stocking rates (SR) and reduced supplementary feed usage. National statistics reveal that the number of dairy female cattle generated by the Irish dairy industry has increased by 50% over the last five years and indicate that Irish dairy farmers have already commenced preparations for milk production expansion and the removal of

EU milk quotas in April 2015. As dairy herds expand and farm SR increases, this will place additional feed supply pressures on dairy farm businesses. Increased operational scale must not result in a significant reduction in either the length of the grazing season or individual animal lactation lengths as these effects would likely increase milk production costs and reduce the profitability of milk production. Recent research at Curtin's Farm, Teagasc Animal and Grassland Research & Innovation Centre, Moorepark, has been investigating the likely effects of changes in SR and herd-calving date on the productivity of Irish grass-based milk production systems post-(EU) milk quotas. The main findings from the first three years of this experiment are reported here.

### Why are stocking rate and herd mean calving date so important?

Achieving high levels of milk production from grazed grass with minimal supplementation will occur where the appropriate mean calving date and distribution of calving is achieved in conjunction with the optimum SR to align feed supply to herd demand. Stocking rate is traditionally defined as the number of animals per unit area of land (livestock units (LU)/ha) and is best considered as a balancing act between feed supply (the amount of grass grown in this case) and herd demand (the number of cows needed to eat the grass grown). Stocking rate is acknowledged as the main driver of milk production from grazing systems due to its impact on milk and milk solids production per hectare and on the amount of grass that is utilised (eaten) per hectare.

A recent review of the published scientific literature indicates that as SR increases, milk production per cow declines but milk production per hectare increases. Calving date is also an important factor in grass-based milk production systems and influences both the productivity of the dairy herd (lactation length) and also the requirement for supplementation in grazing systems. The average stocking rate (SR = 1.9 LU/ha) and mean calving date (MCD = March 15) of Irish dairy farms differs considerably from Teagasc dairy research herds (SR = 2.5 – 3.3 LU/ha and MCD = February 15). Therefore, there is considerable scope to increase productivity on Irish dairy farms post-quotas.

### Curtin's Farm experiment

The study at Curtin's Farm is testing the productivity and profitability of a range of SR systems (Low: 2.51 LU/ha; Medium: 2.92 LU/ha and High: 3.28 LU/ha) and two compact herd calving dates (mean calving dates February 14 and March 1). The study is currently in year four and includes high EBI Holstein-Friesian cows (EBI = €154). The overall study objective is to identify the optimum overall farm SR and mean calving date combination to deliver the greatest financial return to the dairy farmer. The low SR treatment was designed to allow each animal to express its milk production potential, unrestricted by limitations in feed supply (target post-grazing residual sward height, 4.5-5.0cm). While foregoing individual animal performance, the aim of the medium and high SR treatments is to investigate the potential to increase milk production per hectare through increased herbage utilisation at higher SR through increased grazing intensity. (The target post-grazing residual sward heights were 4.0 - 4.5 cm and 3.5 - 4.0 cm for the medium and high SR treatments, respectively).

### Milk production performance

The overall milk production performance of each of the three stocking rate treatments was consistent over the three years, and is similar to that reported in previous experiments with Holstein-Friesian dairy cattle at Moorepark. Stocking rate had a significant effect on milk and milk solids yield per cow and per hectare over the three years while calving date had little effect (Table 1). The low SR treatment produced the greatest amount of milk and milk solids yield per cow but the lowest amount of milk and milk solids per hectare. In contrast, the high SR produced the lowest amount of milk and milk solids per cow but the highest amount of milk and milk solids per hectare, with the medium stocking rate being intermediate.

Table 1: Milk production performance of the Curtin's Farm herd (2009-2011).

Calving group	Early			Late		
	Low	Medium	High	Low	Medium	High
Lactation length (days)	293	290	290	281	274	276
Milk yield (kg)	5,811	5,434	5,110	5,862	5,416	5,265
Milk solids yield (kg)	457	426	408	460	418	415
Milk yield (kg/ha)	14,589	15,978	16,803	14,817	15,921	17,275
Milk solids yield (kg/ha)	1,144	1,249	1,338	1,162	1,227	1,359

### Herbage production and utilisation

As Irish dairy farmers increase overall farm SR, this will generally result in an increase in grazing intensity and overall grazed grass utilisation. Consequently, detailed grazing measurements have been undertaken as part of the Curtin's Farm SR experiment over the last three years to further understand the important implications of overall farm SR and grazing intensity on grass production, quality and utilisation. These results are presented in Table 2 below. The results of the study indicate that, although having only a small effect on total feed utilisation, increasing SR results in increased grazed grass utilisation and improved overall grass quality.

Table 2: Effect of stocking rate on grass utilisation and quality (2009-2011).

Calving group	Early			Late		
	Low	Medium	High	Low	Medium	High
Pre-grazing sward height (mm)	82.4	81.0	80.8	84.4	79.8	80.7
Post-grazing residual height (mm)	43.0	38.2	34.3	43.8	38.8	35.1
Grass utilisation (tons DM/ha)						
Grazed grass utilised	8.8	9.5	9.8	9.0	9.2	9.8
Silage produced	2.8	2.3	2.2	2.8	2.3	2.2
Total grass utilisation	11.6	11.5	12.0	11.8	11.5	12.0
Grass Quality (g/kg)						
Organic Matter	748	752	766	748	752	766
Digestibility						
Crude Protein	207	209	213	207	209	213

### Implications for industry and future work

The results of this study clearly highlight the overall benefit of increased stocking rates in comparison with the average SR of Irish dairy farms. As farmers increase SR, total milk output from the dairy farm will increasingly be limited by grass growth and so, the development of grazing management practices to improve grass production and quality will take precedence over practices informed by individual animal performance. Grazing (and nutrient) management to support higher SR post-milk quotas will be concerned with achieving adequate soil fertility, reseeding under-performing swards and grazing intensity. Consequently, ongoing studies are focusing on grazing strategies to further increase grass DM availability and utilisation on each hectare of farmland available for milk production.

*This research was funded by Teagasc core funding, the Teagasc Walsh Fellowship Scheme and the Dairy Research Fund.*

# Liver fluke in Irish dairy herds

With the use of a bulk tank milk ELISA technique, researchers have found a high proportion of Irish dairy herds antibody-positive to liver fluke.

*Fasciola hepatica* (liver fluke) is a parasite that lives in the bile ducts and livers of a wide range of mammals. Worldwide, liver fluke disease is estimated to result in the loss of €2.5 billion per annum (Doherty, 2010). This substantial economic loss can be attributed to liver condemnations, lost productivity and mortality. While infection with this parasite has major health and welfare implications, particularly in small ruminants, in dairy cows liver fluke infection can go unnoticed and untreated.

and eggs are evident in the ruminant faeces. A recent study reported two seasonal transmission peaks, as shown by the presence of mature infection in snails, namely summer/autumn and late winter/early spring (Relf, et al., 2011). While seasonal patterns of liver fluke infestations in dairy cows have been studied in other countries, published information in Ireland is limited. Also, data on the prevalence of liver fluke in Irish dairy cows is largely restricted to the most recent study carried out by Murphy et al. (2006), which highlighted that 65% of livers from culled dairy and beef animals were infected. The objective of this study, therefore, was to document the seasonal pattern and prevalence of *F. hepatica* in Irish dairy herds through the detection of antibodies in bulk milk tank samples.

## Liver fluke life cycle

Ireland's warm, wet climate and grassland-based animal production systems is favourable to the perpetuation of the liver fluke life cycle (Figure 1). It takes approximately 12-14 weeks, from the ingestion of metacercariae on grass, before infection is patent

## Prevalence study

Bulk milk sampling kits were mailed to 290 dairy farmers across Ireland, recruited according to herd size and location from HerdPlus®, a breeding information decision-support tool for farmers coordinated by the Irish Cattle Breeding Federation (ICBF). The history of fluke on these farms was

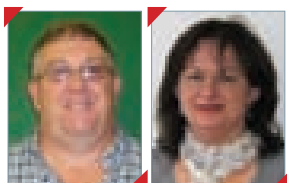

**Yris Bloemhoff,**

Teagasc Walsh Fellow,

**Riona Sayers,**

Herd Health Research Officer and

**Noel Byrne,**

Animal Health Technician,  
Animal and Grassland Research  
& Innovation Centre, Teagasc,  
Moorepark.

**Dr Barbara Good,**

Senior Research Officer, Animal  
and Grassland Research &  
Innovation Centre, Teagasc,  
Athenry.

Correspondence:

yris.bloemhoff@teagasc.ie

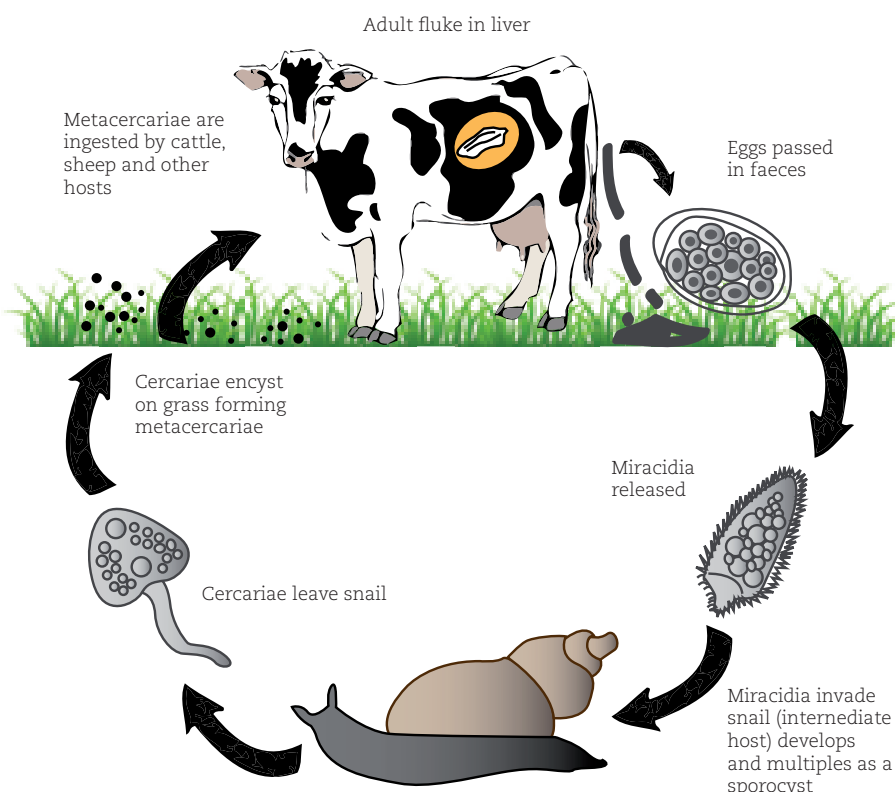

Figure 1: Life cycle of liver fluke. After Animal Health Ireland.



unknown. Samples were collected at four time points (March, June, August, and November) over the 2009 lactation and returned to Teagasc, Moorepark. The milk sample was de-fatted and tested with a commercially-available ELISA (BoFinn Diagnostics, Ireland). The results were recorded as a ratio of sample/positive control x 100 with a positive cut-off value of 15 sample/positive.

### Results of herd antibody prevalence study

The proportion of farms positive for fluke in March, June, August and November were 52%, 54%, 62%, and 75%, respectively. Nearly half (47%) of the dairy farms had positive results on all four sampling dates, while only 25% had negative results on all four sampling dates. The November result is in agreement with the prevalence level observed of bulk milk samples taken in winter in England (72%) (McCann et al., 2010). In contrast, the prevalence of *F. hepatica* antibodies in Flanders, Belgium in the autumn was much lower (37.3%) (Bennema et al., 2009).

### Seasonal pattern study

In a separate study, 29 dairy farms were monitored monthly from March 2009 to 2010. This consisted of seven Teagasc research herds and 22 commercial Munster-based dairy farmers (DairyMIS discussion group). As a result of the dry period, only nine farms submitted samples in January 2010 and no samples were available in February. The overall pattern of *F. hepatica* antibodies is shown in Figure 2. A decline in *F. hepatica* antibodies was observed from April to July 2009, followed by a subsequent increase to January 2010. By March 2010 (no information is available for Feb. 2009) the *F. hepatica* antibody levels were similar to those recorded in March 2009. The rise of antibody levels from August is likely a response to the increased challenge on pasture (summer/autumn infection of pasture by snails).

### What does this mean for our dairy herds?

The proportion of dairy herds with antibodies to liver fluke in the prevalence study is high. The seasonal pattern, highlighted in this study, shows that the use of bulk tank milk ELISA for the detection of liver fluke is a very convenient, cost-effective, and valuable technique to establish a herd's liver fluke status. When applied, at a number of time points over the lactation, it proves a useful tool for dairy farmers and their veterinary practitioners to design an appropriate fluke control programme for individual farms. While there are management measures to reduce the exposure to liver fluke, such as improving drainage, and/or fencing off wet areas, and/or reducing the amount of poaching, the control of liver fluke in Ireland is primarily based on the use of flukicides (Animal Health Ireland, 2011).

### Relevance to the dairy industry

Since 2010, the number of flukicides permitted for use in dairy cows has been restricted. A list of approved preparations of albendazole and oxcyclozanide, the only active ingredients still available for use in lactating dairy cows (strict adherence to specified withdrawal period is required), is available at [www.imb.ie](http://www.imb.ie). These products are active against mature liver fluke only. Two doses of these active ingredients, separated by a suitable interval (e.g., treatment at

housing and again at calving) should, therefore, be used for optimal treatment. Treatment of liver fluke in spring-calving dairy cows is predominantly carried out during the dry period when cows are housed. Treatment of autumn-calving cows is more problematic, as they are dry during the grazing period and are liable to ingest infected grass unless housed. More recently, a triclabendazole-based product, Fasinex 240, has been licensed for use in dairy cows in Ireland, which kills not only mature but also early immature and immature liver fluke (Boray et al., 1983). It should be noted, however, that Fasinex 240 is indicated for the treatment of dairy cows for liver fluke infection during the dry period only. As with all veterinary medicines, product-specific milk withdrawal periods for flukicides must be strictly observed. Further information on individual products, licensing, and withdrawal periods for veterinary medicines is available from the Irish Medicines Board ([www.imb.ie](http://www.imb.ie)).

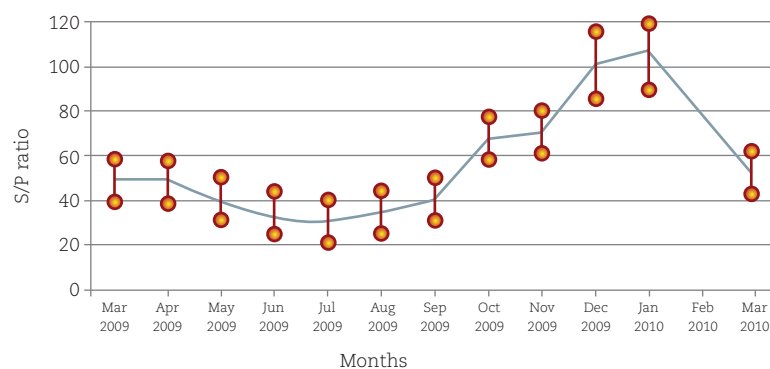

Figure 2: Average bulk tank milk antibody levels on DairyMIS farms.

### Acknowledgements

The authors thank the participating dairy farmers, ICBF and Animal Health Ireland for their contributions to these studies. This research was funded by Merial, France, the Irish Dairy Levy Fund and Teagasc's Walsh Fellowship programme.

### References

- Animal Health Ireland. (2011) 'Liver fluke the facts' Animal Health Ireland, Parasite leaflet No 5, Version 1 July 2011. Available from: [www.animalhealthireland.ie](http://www.animalhealthireland.ie)
- Boray, J.C. et al. (1983) 'Treatment of immature and mature *Fasciola hepatica* infections in sheep with triclabendazole'. *Veterinary Record* 113: 315-317.
- Bennema, S. et al. (2009) 'The use of bulk-tank milk ELISAs to assess the spatial distribution of *Fasciola hepatica*, *Ostertagia ostertagi* and *Dictyocaulus viviparus* in dairy cattle in Flanders (Belgium)'. *Veterinary Parasitology* 165: 51-57.
- Doherty, M. (2010) '€2.5 billion losses from liver fluke worldwide' Animal health announcement. *Irish Farmers Journal* (6/11/2010).
- McCann, C.M., et al. (2010) 'Seroprevalence and spatial distribution of *Fasciola hepatica*-infected dairy herds in England and Wales'. *Veterinary Record* 166: 612-617.
- Murphy, T.M. et al. (2006) 'A study of helminth parasites in culled cows from Ireland'. *Preventive Veterinary Medicine* 76: 1-10.
- Relf, V. et al. (2011) 'Temporal studies on *Fasciola hepatica* in *galba truncatula* in the west of Ireland'. *Veterinary Parasitology* 175: 287-292.



# Quality traits for recommended grasses



Researchers have developed a new technique for providing estimates of quality traits for the recommended list of grass varieties.



Grass is the most cost-effective forage available to Irish farmers due to its ability to successfully provide energy, protein and other nutrients to ruminants throughout a relatively long growing season. It can persist and remain productive over many years and this reflects how well it is suited to our mild maritime climate. Grass is invariably used as a forage within livestock production systems that involve either:

- (a) grazing throughout the grass growing season, or
- (b) conserving grass as silage in the earlier to middle part of the year and grazing preceding and subsequent growths. In order to best exploit the opportunities provided by grass, it is important to select species and varieties that best match sward productivity, quality and persistence with the requirements of our livestock production systems. The ability to choose the correct grass species and variety requires specific information, and this is provided by a grass evaluation programme that is operated by the Department of Agriculture, Food and the Marine (DAFM).

Traditionally, DAFM evaluated ryegrass varieties

based on key agronomic characteristics, such as yield and persistence. This provided an assessment of how suited these varieties were for Irish livestock production systems. The culmination of this work has been the annual publication of 'The Recommended List of Grass and Clover Varieties for Ireland' ([www.agriculture.gov.ie](http://www.agriculture.gov.ie)).

For many years, herbage production has been considered the most important trait for variety evaluation, but recently, grass breeders have also achieved success in improving some quality traits of grass varieties. These have the potential to improve livestock production and/or environmental characteristics. Consequently, DAFM has been keen to improve its recommendations by also examining quality attributes of grass varieties. These include nutritive value indices such as *in vitro* dry matter digestibility (DMD) and crude protein (CP) concentration, and grass ensilability indices such as water-soluble carbohydrates (WSC) concentration and buffering capacity. In addition, dry matter (DM) concentration values are assessed.

## Measuring grass quality indices

Until relatively recently, the only means of measuring grass quality indices was by highly skilled, expensive and relatively slow laboratory reference methods. This would be a major limitation for the DAFM grass evaluation programme, as substantial

**Dr Gareth Burns,**  
Walsh Fellow and

**Dr Padraig O'Kiely,**  
Research Scientist, Animal and  
Grassland Research & Innovation  
Centre, Teagasc, Grange

**Dr Trevor Gilliland,**  
Head, Agri-Food and Biosciences  
Institute Plant Testing Station,  
Co Down.

**Dermot Grogan,**  
Department of Agriculture, Food  
and the Marine, Backweston,  
Co Kildare.

Correspondence:  
[padraig.okiely@teagasc.ie](mailto:padraig.okiely@teagasc.ie)

Table 1: Summary of optimal calibration models for predicting four grass quality attributes.

Attribute	n	Mean	SD	SEC	R <sup>2</sup>	Validation		
						SEP	SEP %	R <sup>2</sup>
BC	1985	428	93.1	20.3	0.952	21.2	4.95	0.953
CP	1941	149	37.1	5.0	0.982	5.3	3.56	0.980
DMD	1986	798	43.1	15.9	0.864	16.0	2.01	0.845
WSC	1941	182	53.0	10.4	0.961	11.4	6.26	0.956

BC - Buffering capacity (mEq/kg DM); CP - Crude protein (g/kg DM); DMD - *in vitro* dry matter digestibility (g/kg); WSC - Water-soluble carbohydrate (g/kg DM); SD - Standard deviation; SEC - Standard error of calibration; SEP - Standard error of prediction; SEP % - Standard error of prediction as percentage of the mean.

Table 2: Summary of effects of ploidy and maturity on DMD, WSC and CP of perennial ryegrass in simulated grazing plots from a combined simulated grazing and conservation management regime.

	Spring grazing			Aftermath grazing		
	DMD	WSC	CP	DMD	WSC	CP
Ploidy						
Diploid	840	236	161	793	172	153
Tetraploid	854	256	157	804	183	151
Significance	***	***	***	***	***	***
Maturity (heading) class						
Early	852	213	177	791	161	162
Intermediate	853	212	183	786	161	163
Late	846	226	182	796	170	155
Significance	N.S.	N.S.	N.S.	N.S.	N.S.	N.S.

DMD - *in vitro* dry matter digestibility (g/kg); WSC - Water soluble carbohydrate concentration (g/kg DM) CP - crude protein concentration (g/kg DM). N.S. - Non-significant; \*\*\* - Highly significant.

numbers of samples are generated each year. Consequently, if quality attributes were to be routinely examined in the DAFM evaluation scheme, a much faster and more labour-efficient approach needed to be developed.

Near infrared reflectance spectroscopy (NIRS) is a technology that is ideally suited to assessing quality attributes of large numbers of samples that are generated in the DAFM evaluation scheme, as it provides rapid results while minimising laboratory costs. NIRS is a predictive technique that relies on calibration models with known reference values to provide assessments of quality, based on spectral data.

In this study, over 15,000 grass samples were analysed by NIRS and a sub-sample of 2,076 were selected and analysed using reference laboratory methods to develop NIRS calibration models. A total of 220 calibration models were assessed in order to produce the most accurate and robust models (Table 1). These calibration models were used to measure quality assessments of the full database of grass samples of varying ryegrass species, ploidy, maturity and age of sward. Further assessment was carried out on the effects these factors had on the quality of grass.

### Key findings

A technique that grass breeders employ to improve the quality of grass varieties is the creation of tetraploid varieties. Tetraploid varieties have double the normal number of chromosomes of naturally occurring grasses and this change in ploidy causes several key physiological and morphological adaptations. For example, a tetraploid variety has larger sized cells without a proportional increase in cell wall material, and this can result in improved digestibility and WSC content compared to diploid varieties.

The assessment of ryegrass varieties evaluated by DAFM confirmed

Table 3: Summary of the ensilability traits of three ryegrass species in their first harvest year.

Species	First silage cut			Second silage cut		
	BC	WSC	DM	BC	WSC	DM
Perennial ryegrass	446 <sup>a</sup>	159 <sup>a</sup>	162 <sup>a</sup>	359 <sup>a</sup>	145 <sup>a</sup>	189 <sup>a</sup>
Italian ryegrass	375 <sup>b</sup>	196 <sup>b</sup>	200 <sup>b</sup>	293 <sup>b</sup>	183 <sup>b</sup>	215 <sup>b</sup>
Hybrid ryegrass	401 <sup>b</sup>	185 <sup>b</sup>	195 <sup>b</sup>	281 <sup>b</sup>	195 <sup>b</sup>	227 <sup>b</sup>

BC - buffering capacity (mEq/kg DM); WSC - water soluble carbohydrate concentration (g/kg DM); DM - dry matter (g/kg). Different superscript letters within a column indicate significant differences.

this. The DMD and WSC concentration of tetraploid varieties was higher than diploid varieties when assessed under simulated grazing conditions in spring and autumn (Table 2), and this would be expected to result in greater animal production from similar levels of herbage intake. The CP concentration of diploid varieties was statistically higher than tetraploid varieties, although it is unlikely that there would be an animal production response to the modest scale of difference identified. Under these conditions maturity class had no effect on the quality of the sward.

A combination of buffering capacity, water-soluble carbohydrate concentration and dry matter concentration can provide an indication of the ensilability of grass species. The information gleaned from the database related to the ryegrasses evaluated by DAFM shows that Italian ryegrass displayed better ensilability characteristics than perennial ryegrass, with hybrid ryegrass being intermediate but more similar to Italian ryegrass (Table 3). The ensilability traits of these three commonly sown ryegrass species are better than those of other grass species found in permanent pastures, and justify their selection for leys intended for ensilage.

In addition, this research explored relationships between nutritive quality attributes and found that these relationships varied between ryegrass species and varieties. There is the potential to use this information to identify the optimum ratio of forage quality characteristics that can improve animal productivity and efficiency of livestock systems.

### Benefits to Irish agriculture

As a result of this research, Teagasc Grange now provides the analysis of quality attributes for the grass samples being evaluated by DAFM. However, it is important to note that whereas the NIRS calibrations developed are appropriate for the DAFM sample set, they are likely to be unsuited for predicting the composition of other grass samples.

A key output of this research has been the inclusion of both DMD and WSC in the Irish List of Recommended Grass Varieties. An additional benefit is the ability to monitor breeding progress in grass CP and buffering capacity, with the option to include them as part of the recommendation for any ryegrass variety that is notably extreme in these quality characteristics. Overall, the ability to measure quality traits has provided Irish farmers with improved information with which to choose the optimal varieties of ryegrass to match their requirements, and has put DAFM at the forefront of grass varietal evaluation.

### Acknowledgements

This research was funded by the National Development Fund under the Research Stimulus Fund. The authors also acknowledge the laboratory staff at Teagasc Grange and the field staff at DAFM Backweston, Co Kildare.

# Dublin City of Science



Dublin has been designated as European City of Science for 2012. During the year, a large number of scientific events will be organised in Dublin and nationally in order to showcase Ireland's growing capacity in science.

Teagasc is contributing to this programme by way of a series of conferences, workshops, exhibitions, schools visits, etc. These events will be branded with the City of Science logo and will be promoted through the City of Science website.

## December

5 December

Farmleigh, Dublin

### National Agri-Environment Conference 2012

This year's Agri-Environment Conference will examine the concept of sustainable intensification and how the Irish agri-food sector can develop sustainable farming solutions that balance economic and profit imperatives with environmental outcomes.

An exciting line up of speakers will include: Michael Hamell from DG Environment; Pdraig Brennan, Bord Bia; Al Grogan, DAFM; and, Audrey O'Shea, Glanbia.

Contact: mark.gibson@teagasc.ie

6 December

Lyrath Estate Hotel, Kilkenny

### National Agricultural Energy Efficiency Conference 2012

Jointly organised between Teagasc, SEAI, *Farming Independent* and Macra na Feirme, the theme of this inaugural conference is 'Energy Smart Farming'. Topics for discussion will include carbon foot-printing in agriculture; energy saving options, as well as practical and insightful case studies highlighting the dos and don'ts of running a renewable project. Suppliers of cutting-edge products, services and technology for the renewables market will be on-hand to offer advice and the conference will be an opportunity to network with industry bodies and policy makers, energy suppliers, generators and users as well as installers, suppliers and manufacturers.

Contact: barry.caslin@teagasc.ie

10 December

Davenport Hotel, Merrion Street Lower, Dublin 2

### Economic Review and Outlook Seminar

As the 2012 farming year draws to a close, the Teagasc economics unit will review the year just finishing and present their outlook for the farming sectors for the year ahead. At an event in Dublin on 10 December, presentations will be made on the macroeconomic outlook, a review of agricultural income, outlook for output and input markets, income forecasts for 2013 and CAP reform. Speakers will include Thia Hennessey, Trevor Donnellan, Kevin Hanrahan, Michael McKeon, Teagasc and Fergal O'Brien from IBEC.

Contact: marian.moloney@teagasc.ie

12 December

Teagasc Food Research Centre, Moorepark, Fermoy, Co Cork

### Food Innovation Gateways

This one-day event will allow food companies to explore opportunities that exist, including tax incentives and supports for research and development. A presentation from Bord Bia will outline existing market supports for food innovation in Ireland. Contact Niamh O'Brien, Tel: 025 42313 or Lynn Fahy, Tel: 025 42634. Email gatewaysteagasc@teagasc.ie

December 14

UCC, Cork

### Gluten-Free Food Products - Guidance for Industry Workshop

Professor Elke Arendt, University College Cork in partnership with the Fraunhofer Institute, Germany and supported by the European Union presents a

workshop on gluten-free food products. The workshop will provide an overview of the latest research in the gluten-free market. Dr Eimear Gallagher, Ashtown Food Centre, Teagasc, will discuss novel approaches in the development of gluten-free cereal products, while Helen King, Bord Bia, will give an overview into the latest consumer trends. There will also be a visit to the food processing facilities, at the School of Food and Nutritional Sciences, University College Cork. Contact Mary McCarthy-Buckley: m.mccarthybuckley@ucc.ie

## January

31 January

Lyrath Hotel, Kilkenny

### National Tillage Conference 2012

This conference will provide the opportunity to discuss the ambitious opportunities for expanding the Irish tillage industry identified by the Teagasc tillage and energy stakeholders group and address the most pressing issues for increasing output and controlling costs on Irish tillage farms. Andy Doyle from the *Irish Farmers Journal* will briefly outline the opportunities identified in the tillage sector development plan and the audience will have the chance to put questions to a panel of industry experts. The team from Oak Park will then outline ways that tillage growers can improve yields and margins to exploit the potential.

## March

11- 12 March

Tullamore Court Hotel, Tullamore, Co. Offaly

### Agricultural Research Forum

This annual two-day event will feature all the latest agricultural research from the major research institutes on the island of Ireland. The objective of the meeting is to provide an opportunity for the presentation and publication of new scientific information relating to the Sciences of Agriculture (including animal and crop science, molecular biology and biotechnology), Environment, Soil, Food, Agri-Economics and Forestry. The conference places an emphasis on novel, high quality research and on the professional presentation of results. The forum will provide an opportunity for scientists, specialists, advisors and others working in the above areas to interact and exchange views. Participation by industry personnel is particularly welcome.

Contact Michael Diskin: michael.diskin@teagasc.ie

14 March

RDS, Dublin

### Teagasc Lecture Series – Lecture 3: Sustainable Intensification and the Role of

### Science and Technology in Meeting the Food Security Challenge

Professor Charles Godfray, Professor of Zoology at Jesus College, Oxford and Director of the Oxford Martin Programme on the Future of Food will deliver the third lecture of Teagasc's Lecture Series. Professor Godfray is interested in how the global food system will need to change and adapt to the challenges facing humanity in the 21st century, and, in particular, in the concept of sustainable intensification, and the relationship between food production, ecosystem services and biodiversity. His lecture will explore the role science and technology will play in achieving the transitions required to make the global food system more efficient and resilient. It will discuss the opportunities that technologies, such as biotechnology, nanotechnology, ICT, and agro-ecology, hold for increased efficiency of future agri-food-systems.

<http://www.teagasc.ie/events/ids-lecture-series/index.asp>